

# 15 SOFTWARE CONFIGURATION

The Steffes Comfort Plus Hydronic system has a Configuration Menu, which allows it to be customized to the power company and consumer's needs. This menu can be accessed on start-up and allows configuration settings to be easily adjusted.

## Accessing the Configuration Menu

- Step 1** Energize the system. Access to the Configuration Menu is allowed for the first two (2) minutes of operation. If the system has been energized for over two (2) minutes, it must be powered off and back on again.
- Step 2** Press and release the **M** button until the faceplate displays "CONF."
- Step 3** Press the up arrow once and the faceplate will display "C000." The display will flash between "C000" and the corresponding configuration value.

## IMPORTANT

If access to Configuration Menu times out, the 15 amp circuit breaker must be powered off and back on to re-enter the menu.

- Step 4** If necessary, edit the configuration by pressing and holding the **M** button while using the up or the down arrow button to change the value.
- Step 5** Once the value is correct, release the buttons and press the up arrow button to go to the next configuration (C001, C002, etc.).
- Step 6** Repeat steps 4 through 5 until all configuration settings have been adjusted to the desired values.
- Step 7** Once configured, use the down arrow to leave the Configuration Menu.

In most applications only a few, if any, configuration changes will be necessary. Following is a description of the configuration settings and their functions:

- C000 Off-Peak Method of Charge Control** - A value of five (5) configures the system for automatic charge control.
- C001 Start Brick Core Charge Set Point** - Outdoor temperature at which the system will start charging.
- C002 Full Brick Core Charge Set Point** - Outdoor temperature at which the system will target a full core charge.
- C003 Power Line Carrier (PLC) Channel Selection**
- C004 Optional Controls Configuration**

Value	Configuration Description
8	No Outdoor Sensor/No Time Clock Module
9	Outdoor Sensor/No Time Clock Module
12	No Outdoor Sensor/Time Clock Module
13	Outdoor Sensor/Time Clock Module

**C005 Control Switch Configuration** - If utilizing power line carrier control, the Steffes time clock module or line voltage control, this value should be zero. For all other applications, this value should be one (1).

## C006 Output Control Configuration

Value	Configuration Description
2	All Comfort Plus Hydronic systems
8	Compressor control if "COOL" call during peak (control) time
32	Compressor cycling (off 20 minutes, on 20 minutes)
128	Interface Comfort Plus Hydronic to heat pump with reversing valve energized for heating

**C007 Charge Factor** - This configuration should be set to a value of thirty (30).

**NOTE: C008 - C010 only applicable if the Comfort Plus Hydronic system is being used with a heat pump.**

**C008 Heat Pump Compressor Outdoor Lock-Out Temperature for Off-Peak** - Outdoor temperature at which heat pump's compressor is locked out and not allowed to operate during off-peak period.

**C009 Heat Pump Compressor Outdoor Lock-Out Temperature for On-Peak** - Outdoor temperature at which heat pump's compressor is locked out and not allowed to operate during on-peak period.

**C010 Minimum Discharge Air Temperature** - Stage 1 heat call.

**C011 Maximum Outlet Water Temperature**

**C012 Minimum Outlet Water Temperature**

**C013-C021 Time Clock Module Configuration** - Refer to the installation and configuration instructions included with the module for more information.

## CAUTION

Risk of property damage. Improper water temperature settings can result in damage to the floor covering. Make sure the maximum and minimum water temperatures are appropriate for the application.



"Manufactured in North America"

# COMFORT PLUS HYDRONIC Models 5120, 5130, 5140



## Quick Reference Installation Sheet

### 1 PLACEMENT AND CLEARANCES

#### WARNING

If area available to install Comfort Plus Hydronic system is less than 100 square feet, consult factory. If installing in area with less than 400 square feet, ventilation MUST be provided. Temperature in area should be maintained at or below 85°F.

- Minimum Clearance Requirements**
- A Back and Right Side = 3 inches from combustibles
  - B Front = 36 inches
  - C Top = 6 inches from combustibles
  - D Bottom = 1 inch from combustibles
  - E Left Side = 36 inches

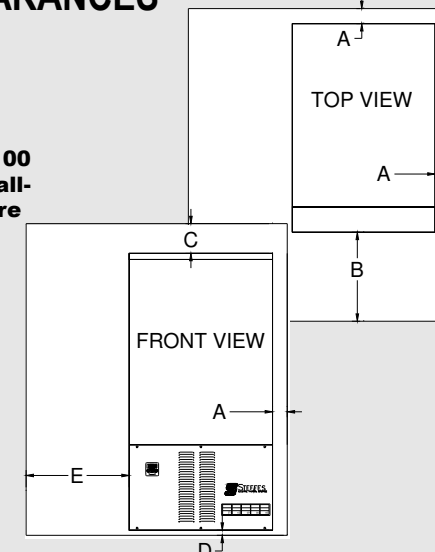

### 2 SET-UP

- Place system in desired location.
- Adjust leveling legs.
- Remove painted front panel of brick storage cabinet.
- Position element wiring harnesses to avoid damage during brick loading.
- Position brick core temperature sensor(s) to avoid damage during brick loading.
- Remove galvanized front panel.
- Starting at bottom, lift and drape insulation blankets over top of system.
- Remove front air channel by pulling out at top.
- Remove heating elements from inside brick core cavity.

#### CAUTION

- DO NOT** extend leveling legs more than one inch.
- DO** use and follow generally accepted safety practices when handling insulation material.
- Equipment **MUST** be installed by a qualified technician in accordance with all applicable local, state and national codes and regulations.
- Reference Owner's and Installer's Manual for complete safety, installation, and operation instructions.

### 3 BRICK LOADING

Starting at the back of the brick core cavity, load bricks one row at a time using left side, right side, center pattern. Place bricks with grooved side facing up, notch facing forward, and ridges on left and right.

#### IMPORTANT

- Remove loose debris from brick.
- Brick rows **MUST** line up front to back and side to side.
- Use half bricks in proper rows and in correct positions. Back half of brick **MUST** be installed in back rows. Front half (notched brick piece) **MUST** be installed in front rows.

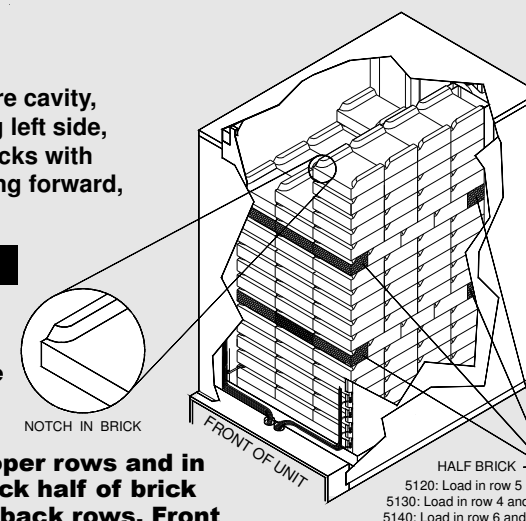

## 4 HEATING ELEMENT INSTALLATION

### ⚠ WARNING

**HAZARDOUS VOLTAGE: Risk of electric shock, injury or death.**

- **DO NOT** remove electrical panel cover while system is energized.
- Elements **MUST** be positioned properly to avoid short circuiting them against any surfaces within system.
- Use care when making connections to avoid element damage.

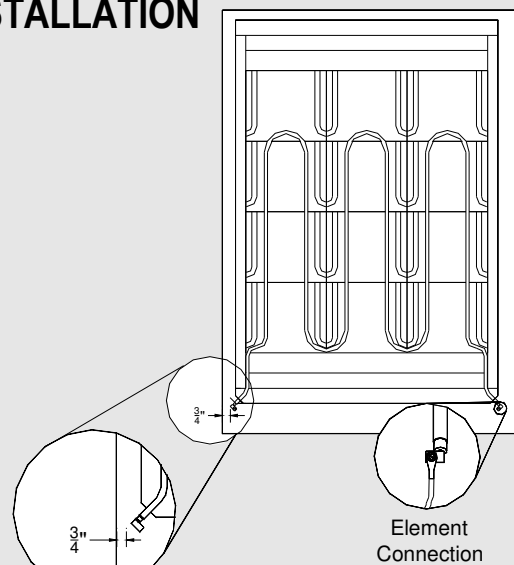

Required Clearance  
Between Element Termination and  
Metal Panels is  $\frac{1}{2}$ " ( $\frac{3}{4}$ " Nominal).

1. Insert heating elements between brick layers until element ends embed into side cutouts of brick cavity. Elements **MUST** be installed with threaded screw tabs on wire connection terminals pointing forward and down.
2. Remove painted panel from electrical compartment and locate the installation hardware package.
3. Connect wiring harnesses to heating elements using screws in hardware package. Install screws with heads up and thread pointing down. Tighten screws to 14 in-lbs.

## 5 AIR CHANNEL INSTALLATION

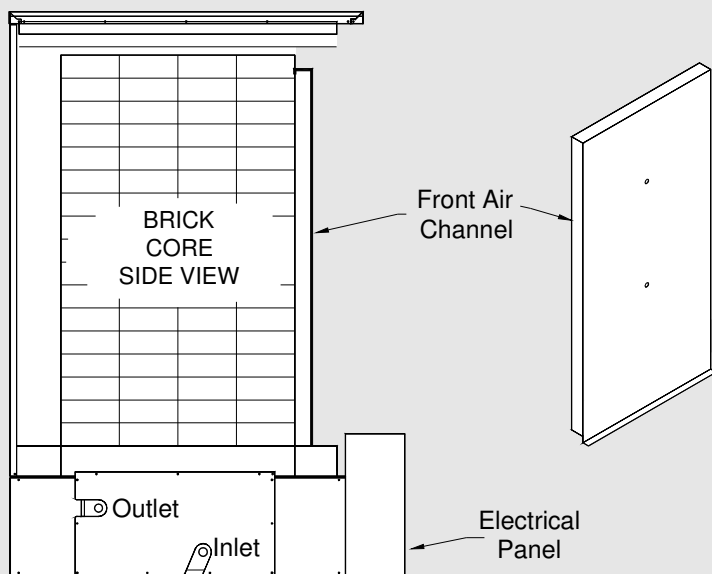

1. Install air channel with air deflectors (arrow shaped pieces) facing inward. Place bottom of air channel in first.
2. Lower insulation blankets back into position, one at a time. Tuck sides into edges, corners and around exposed portions of heating elements.
3. Install galvanized front panel. Slide bottom edge inside lower lip of brick cavity. Top rests on outside of cavity.
4. Check non-insulated element connections to make sure they do not come within 1/2" of any surface.

## 6 BRICK CORE TEMPERATURE SENSOR(S) INSTALLATION

### ⚠ CAUTION

**Risk of improper operation. Proper installation of the brick core temperature sensor(s) is critical to the operation of the Comfort Plus Hydronic system. Read and follow installation instructions carefully.**

1. Remove screw(s) by temperature sensor hole(s) in galvanized front panel.
2. Insert temperature sensor(s) through hole(s). Sensor(s) must pass through blanket insulation and into brick core.
3. Install screw(s) into galvanized front panel to hold sensor(s) and provide electrical ground connection.
4. Inspect sensor wiring for possible short circuiting hazards.
5. Install painted front panel.

**NOTE:** Models 5130 and 5140 have an upper and a lower temperature sensor. Each sensor is marked for proper installation.

## 14 LOW VOLTAGE ROOM THERMOSTAT WIRING

A 24 VAC thermostat must be used (digital recommended).

1. Disconnect power to Comfort Plus Hydronic system. Route low voltage thermostat wire to the system.
2. Insulate thermostat wire wall opening if necessary.
3. Attach thermostat. When using a mechanical thermostat or thermostat with anticipator, resistor kit #1190015 must be installed to ensure proper operation.
4. Route low voltage wire into electrical compartment to 12 position low voltage terminal block.
5. Install electrical panel cover.

### 12 Position Low Voltage Terminal Block Coding

R = Low Voltage Hot	O = Reversing Valve Input
C = Low Voltage Common	O2 = Reversing Valve Output
Y = Compressor/Stage 1 Heat Call	H = Hydronic Heat
W = Stage 2 Heat Call	OS = Outdoor Temperature Sensor
Y2 = Compressor Output	SC = Outdoor Temperature Sensor Common
G = Fan Call	DS = Duct Temperature Sensor

### HEAT PUMP APPLICATION

A Two Stage Heating and  
Single Stage Cooling  
Heat Pump Room Thermostat

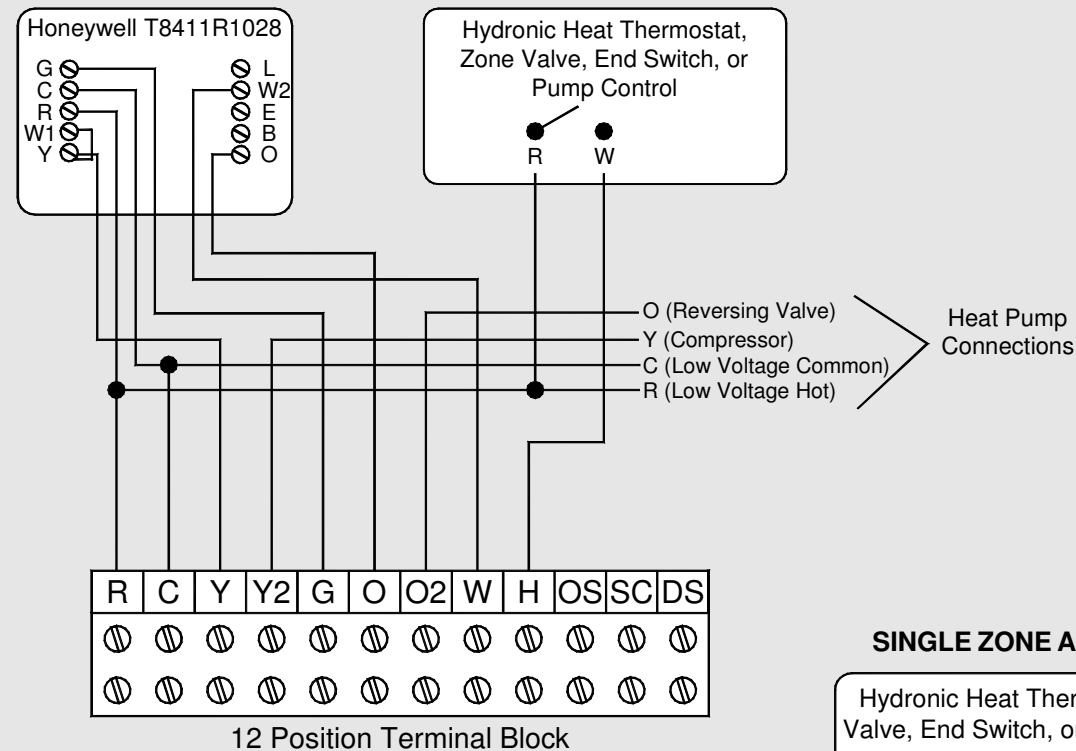

### SINGLE ZONE APPLICATION

Hydronic Heat Thermostat, Zone Valve, End Switch, or Pump Control

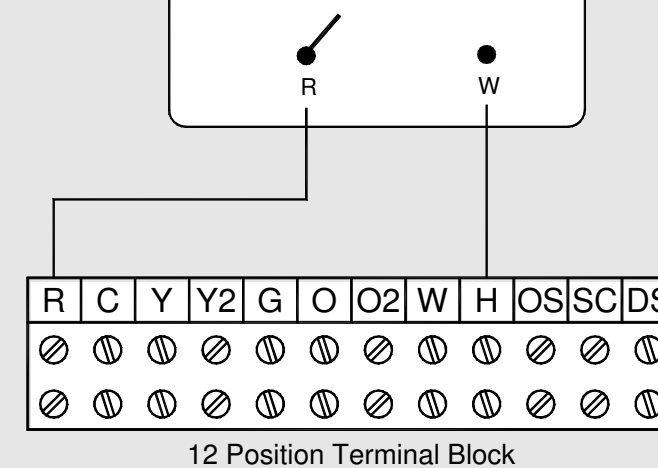

# 11 PRESSURE RELIEF VALVE INSTALLATION

## ⚠ WARNING

Risk of explosion, injury, or death. The factory supplied pressure relief valve **MUST** be connected to the system with the supplied fittings.

- ♦ **DO NOT** modify this assembly.
- ♦ **DO NOT** cap, plug, or otherwise obstruct the outlet of the pressure relief valve.
- ♦ **DO** mount the pressure relief valve in a vertical, upright position.
- ♦ This pressure relief valve is sized to service the needs of the Comfort Plus Hydronic system. If multiple heating systems are being used, pressure relief valving for the other system **MUST** be provided separately.

1. Remove the heat exchanger access panel and locate the pressure relief valve assembly.
2. Using the supplied union fittings, connect the pressure relief valve to the outlet water port on the left side of the Comfort Plus Hydronic system.
3. Use schedule 40 pipe to install a discharge line for the pressure relief valve.
4. Install heat exchanger access panel.

## ⚠ CAUTION

Risk of injury or property damage. During operation, the pressure relief valve may discharge large amounts of steam and/or hot water. To reduce the potential for bodily injury or property damage, install a discharge line.

- ♦ **DO** use schedule 40 pipe for the discharge line.
- ♦ **DO NOT** use schedule 80, extra strong pipe or connections on the discharge line.
- ♦ **DO NOT** cap, plug, or otherwise obstruct the discharge pipe outlet.
- ♦ **DO** follow all local, state, and national codes and regulations.

# 12 LOW VOLTAGE OUTDOOR SENSOR CONNECTIONS

## IMPORTANT

- If connecting to the Steffes power line carrier system, follow the installation instructions in the PLC system's Owner's and Installer's Guide.
- Outdoor sensor wire **MUST NOT** be combined with other control wiring in a multi-conductor cable.

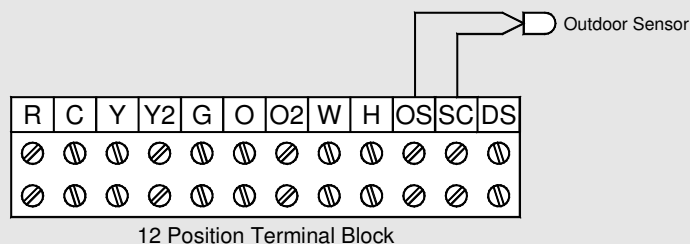

The outdoor temperature sensor can be installed by wiring it directly to the system or to the Steffes power line carrier (PLC) system, if utilized.

### Direct Wired:

1. Mount outdoor sensor in a location where it can accurately sense outdoor temperature.
2. Route low voltage wire from outdoor sensor to electrical compartment:
  - Seal external wall openings.
  - Outdoor sensor lead can be extended to 250 ft.
  - Unshielded Class II (thermostat) wire can be used provided it is segregated from any line voltage wiring.
3. Connect outdoor sensor wires to "OS" and "SC" positions of the 12 position low voltage terminal block.

# 13 LOW VOLTAGE PEAK CONTROL CONNECTIONS

1. Route low voltage circuit from the peak control device to the six position terminal block.
2. Connect field wiring to positions "RP" and "P" on terminal block.

## IMPORTANT

If utilizing a Steffes Time Clock Module or Power Line Carrier control, refer to the installation instructions provided with the device.

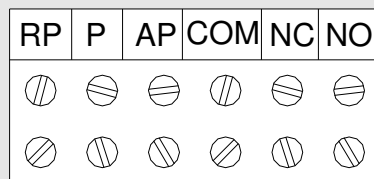

### 6 Position Low Voltage Terminal Block Coding

- RP = Peak Control Input Common
- P = Peak Control Input
- AP = Anticipated Peak (Pre-Peak) Control Input
- COM = Peak Control Output Common
- NC = Peak Control Output (Normally Closed)
- NO = Peak Control Output (Normally Open)

# 7 LINE VOLTAGE ELECTRICAL CONNECTIONS

## ⚠ WARNING

**HAZARDOUS VOLTAGE:** Risk of electric shock, injury or death. Do not energize the Comfort Plus Hydronic system until installation is complete.

1. Route all line voltage wires through knockout(s) and into electrical panel.
2. Make proper field wiring connections.

## IMPORTANT

- To ensure proper operation and safety, all line voltage circuits must be segregated from low voltage wiring.
- To reduce electromagnetic fields associated with electrical circuits and to avoid induced voltage on sensors and electronic devices, the circuit phases **MUST** be alternated as shown below.
- **DO NOT** install any wiring in the line voltage compartment of the Comfort Plus Hydronic system unless it is rated for line voltage.

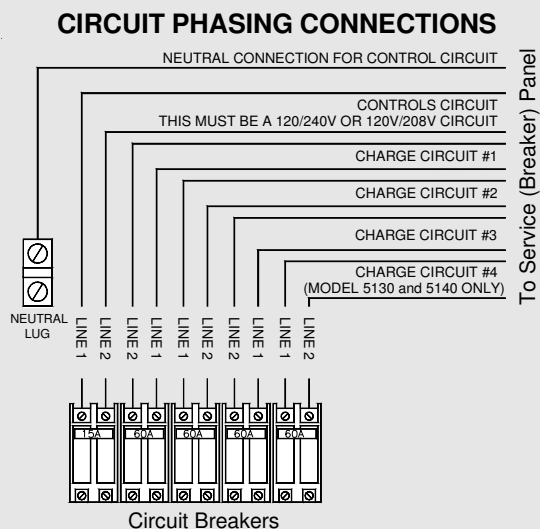

# 8 AIR CONDITIONER/HEAT PUMP INTERFACE

The Air Handler (Order #1302100) is an optional device used to interface the Comfort Plus Hydronic with a ducted heating or cooling system such as a heat pump or air conditioner. The Air Handler includes a plenum assembly, supply air blower, water coil, air filter, wiring harness, and hardware kit. When the Comfort Plus Hydronic system receives a heat call from the room thermostat, it energizes the supply blower and the Air Handler's zone pump.

The Air Handler can be interfaced with a standard heat pump system and will provide comfort modulation. The system will monitor the outlet air temperature and modulate in heat from the Comfort Plus Hydronic as needed to maintain the desired output air temperature.

The maximum coil size the Air Handler can accommodate through the front access is 20" (W) x 22" (H) x 21 3/16" (D). The inner dimensions of the A-coil area are 21 3/16" (W) x 24 1/4" (H) x 21 3/16" (D). If installing a coil larger than the access dimensions, the coil must be placed into the Air Handler during assembly.

## ⚠ WARNING

Risk of fire. Any one ducting system **MUST NOT** contain more than one air handling (blower) system. If the application requires multiple Comfort Plus heating systems or it is necessary to have multiple air handlers share the same ductwork, you **MUST** contact Steffes Corporation. There are special installation requirements that **MUST** be performed in an application such as this.

# 9 JUNCTION BOX INSTALLATION

1. Attach the factory supplied junction box to the left side of the Comfort Plus Hydronic system.
2. Make connections to the primary loop pump and air handler pump inside this junction box. The red and white wires connect to the primary loop pump and the black and white wires connect to the air handler pump. The maximum connected amperage on either of these circuits is 1.2 amps.
3. Attach the junction box cover using the screws provided.

Red & White To Primary Loop Pump (Max 1.2 AMPS)  
Black & White To Air Handler Pump (Max 1.2 AMPS)

*These wires are located on the lower left side of the Comfort Plus Hydronic System.*

## IMPORTANT

If **NOT** utilizing the optional Static Heat Recovery Unit, the orange wire can be used to power a secondary pump.

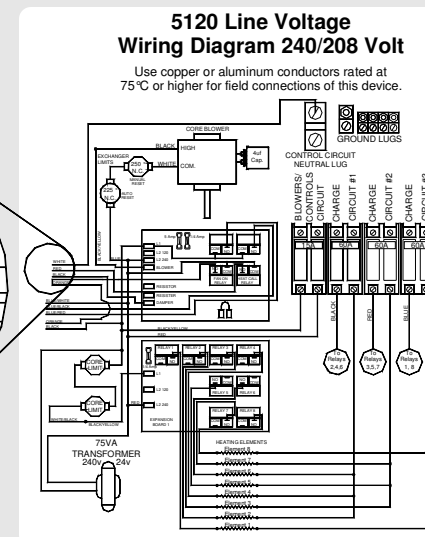

# 10 PLUMBING

The Comfort Plus Hydronic heating system **MUST** be plumbed with a primary loop and secondary (zone) loops. The primary loop needs to consist of a minimum of 10' of 1" pipe and requires its own pump\* (circulator). The secondary (zone) loops require additional pump(s) to operate effectively.

## CAUTION

**FREEZE PROTECTION:** Risk of property damage. Hydronic heating system freeze-ups **WILL** cause extensive damage to the entire heating system and/or property. It is the responsibility of the installer to provide protection against freezing.

**PIPING SUPPORT:** Risk of equipment damage or personal injury. **DO NOT** use the exchanger as support for piping. Support of primary loop and associated plumbing must be installed to ensure proper operation of the system and to keep pressure off the inlet and outlet piping.

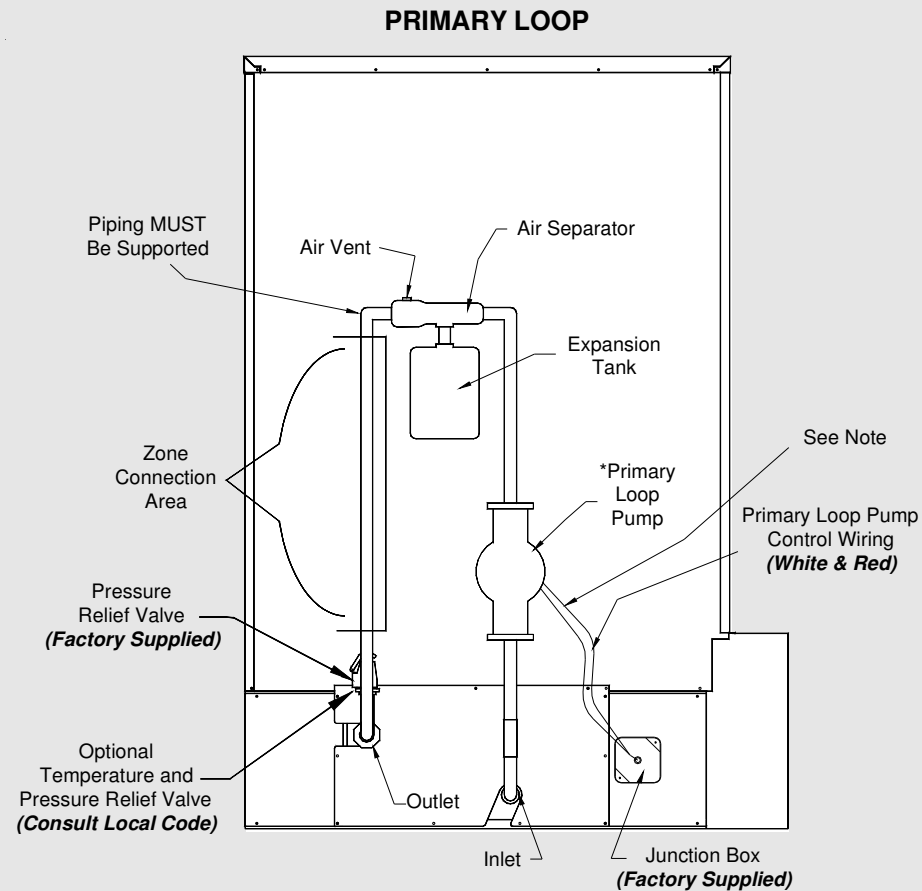

(\* Steffes recommends a Grundfos UP15-42F or equal single speed 115VAC pump for the primary pump.)

PRESSURE DROP THROUGH HEAT EXCHANGER	
STATIC PRESSURE (Feet Water Column)	.1 ft @ 2 GPM
	.2 ft @ 4 GPM
	.4 ft @ 6 GPM
	.7 ft @ 8 GPM
Based on 80 degree entry water temperature with a 50% glycol mix.	1.1 ft @ 10 GPM

TYPICAL FLOOR ZONE DESIGN	
Maximum Length of Pipe per Pipe Size	
3/8"	200'
1/2"	300'
5/8"	500'
(Pipe length will vary by manufacturer.)	

**NOTE:** The primary loop pump **MUST** be controlled by the furnace through the red and white wires. When this pump is running, water must be allowed to flow through the heat exchanger.

## TYPICAL SYSTEM PLUMBING (SHOWN WITH STEFFES AIR HANDLER)

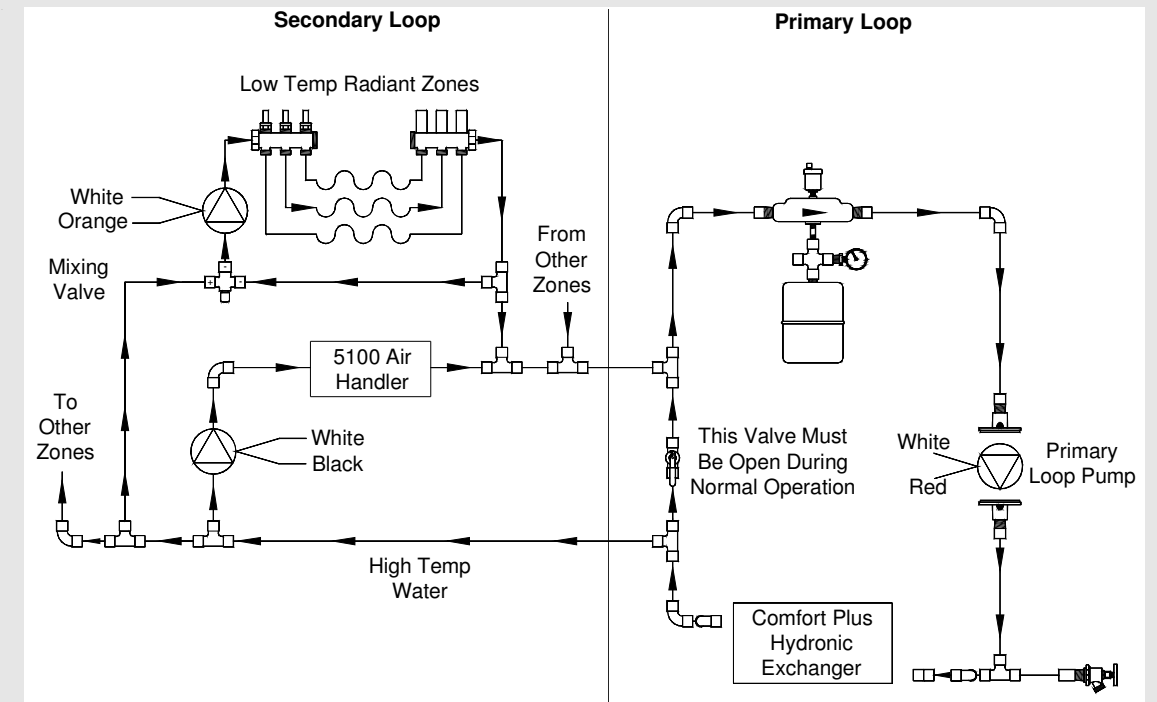

## IMPORTANT

It is the responsibility of the installer to prevent involuntary flow of water to the air handler. Not doing so may cause limit tripping and/or decrease system efficiency. Use of a check valve, zone valve, or other device may help prevent involuntary flow.

## SINGLE TEMPERATURE ZONES

