



"Manufactured in North America"

**OWNER'S AND
INSTALLER'S MANUAL**
for
Double Loop (Central) Furnaces



LISTED

Models: DLF30B & DLF40B

U.S. Pat. #5201024
Can. Pat. #2060881

General Information

General Operation	2
Terminology	3

Safety Information

Safety Precautions	4
Built-in Safety Devices	4

Maintenance and Cleaning

4

Furnace Control Panel

5-6

Operating the Furnace

Furnace Start-up	7
Room Temperature Control	7
Brick Temperature Control (Core Charging)	7-8
How to Turn the Furnace "OFF" and "ON"	8

Installing the Furnace

Shipping	9
Placement	9
Clearance Requirements	10
Furnace Set-up	10-12
Brick Loading	12-13
Installing the Heating Elements	13
Ducting	13-14
Line Voltage Electrical Connections	15-18
Low Voltage Electrical Connections	19-22
Furnace Final Test Procedure	23

Furnace Specifications

24

Exploded View Parts Diagram

25

Furnace Parts List

26-27

Troubleshooting Information

Brick Core Temperature Testing	28
Troubleshooting Guides	29-34

Warranty

- This manual provides information for correct installation procedures and electrical connections for Steffes ETS Double Loop Furnaces, Models DLF30B and DLF40B. The information in this manual will help you utilize the product's many features and ensure many years of safe, reliable operation. Read all the information contained within this manual before installing the system. Store this manual in a safe place for future reference.
- Assembly of and/or service to these units should be performed only by a qualified electrician in accordance with information contained herein and in accordance with national, state, and local electrical codes.
- This manual must be retained by new owners if ownership of the furnace changes.
- Any deviation from these instructions may void the warranty and could result in hazardous operating conditions.
- The warranty registration card provided as part of the unit documentation set must be completed and returned to Steffes Corporation. Failure to do so may adversely affect warranty claims.
- Record the serial number and model number in the spaces provided on the back page of this manual. These numbers are located on the right side of the furnace base, on the shipping box, and on the warranty registration card. Retain this manual for a quick reference to these numbers.
- **DISCLAIMER:** In compiling this manual, Steffes Corporation has used its best judgement based upon information available but disclaims any responsibility or liability for any errors or miscalculations contained herein, or any revisions hereof, or which result, whole or in part, from the use of this manual or any revisions hereof.

1 GENERAL OPERATION

The Steffes ETS Double Loop Central Furnace (DLF) utilizes off-peak electricity which is available during times of the day or night when the power company can supply electricity more economically. By using this off-peak electricity for heating, the power company may offer a special incentive such as a reduced electric rate, an off-peak heating rate, a time-of-use (TOU) rate, or monthly credits on your heating bill.

When off-peak hours are available, the furnace converts electricity to heat which is then stored in its ceramic brick core. The amount of heat stored in the brick core varies in relation to outdoor temperature, owner preference, utility peak conditions, and the requirements of the space being heated. This stored heat becomes available for space heating needs as determined by the wall thermostat that is strategically located in the living space.

When the wall thermostat senses a need for heat, the core blower and supply blower in the furnace operate. The core blower circulates the hot brick air and warms the heat exchanger located in the base of the furnace. The supply air blower circulates room air through the exchanger where it is heated and then delivers it to the conditioned space.

2 TERMINOLOGY

This manual contains terms which may need explanation. The table below lists some of these terms and a brief description of each.

TERM	DEFINITION
Automatic Charge Control	Method of brick core charge regulation where a sensor monitors outdoor temperature to automatically adjust the brick core temperature setting in relation to the outdoor temperature.
Brick Core Charge Level	The amount of heat that is stored in the heater's brick core.
Charge Period	Off-peak time in which the furnace is allowed to store heat in its brick core.
Control Panel	Contains the toggle switches to adjust and display lights to indicate furnace operation. Located on the lower front of the furnace on the electrical panel.
Control Period	On-peak time in which the furnace is not allowed to store heat in its brick core.
Heat Call	When room temperature falls below the room's thermostat setting, the thermostat signals the furnace to operate its blowers and deliver warm air into the space to raise the temperature to the desired thermostat set point.
Heat Exchanger	Device in the base of the furnace where the stored heat from the brick core transfers to the duct system for delivery into the living space.
Manual Charge Control	Method of brick core charging regulation where the user must periodically adjust the brick core temperature setting in relation to the outdoor temperature.
Off-Peak	The time during the day or night when the power company can supply electricity more economically and may offer a special incentive such as a reduced electric rate or billing credits for the electricity consumed during this time. Typically, uncontrollable electrical usage is allowed during this time. (Furnace is allowed to charge or store heat in its brick core during this time.)
On-Peak	The time during the day or night when the power company experiences a high demand for electricity. To limit demand, certain appliances are controlled to avoid usage by them and/or a premium for the electricity consumed during this time may be charged. (Furnace is not allowed to charge or store heat in its brick core during this time.)
Outdoor Temperature Sensor	Device that senses outdoor air temperature and communicates this information to the furnace for automatic charge control.
Peak Override	Enables electrical usage in a device that is typically controlled by the power company during an on-peak time. Some power companies may never permit any controlled devices to be used during an on-peak time. Others that do may penalize the user by charging a premium on energy consumed during this period.

1 SAFETY PRECAUTIONS

1. DO NOT energize the furnace while disassembled or without ceramic heat storage brick in place.
2. As is true with all heating appliances, materials that may produce explosive or flammable gases MUST NOT be used or stored near the furnace.
3. Be sure the minimum clearance requirements specified in this manual are never violated.
4. This unit may be connected to more than one branch circuit. Disconnect power to all circuits before servicing.

2 BUILT-IN SAFETY DEVICES

All Steffes Double Loop Central Furnaces incorporate safety devices to ensure normal operating temperatures are maintained. The chart below describes these safety devices.

DEVICENAME	FUNCTION	LOCATION ON HEATER
Core Charging High Limit Switches	These limit switches monitor brick core charging and will interrupt power to the heating elements if the normal operating temperature is exceeded. Each switch controls two heating elements.	In the limit bar panel on the right side of the brick storage cavity
Heat Exchanger High Limit Switch	This limit switch monitors the temperature in the heat exchanger of the furnace. If the normal operating temperature is exceeded, this switch will interrupt power to the core blower.	In the base of the furnace inside the electrical panel
Core Blower High Limit Switch	This limit switch monitors the discharge air temperature and interrupts power to the core blower if this temperature exceeds 160°F (nominal).	In the supply air plenum assembly on the blower
Supply Air Blower Limit Switch	This limit switch monitors the discharge air temperature and interrupts power to the supply air blower if this temperature exceeds 180°F (nominal).	In the supply air plenum assembly on the blower

Maintenance and Cleaning

The filter in the furnace should be replaced on a regular basis. General cleaning of the furnace's cabinet should be conducted at the user's discretion. No additional routine maintenance is required.

Furnace operation is automatic; however, the user can manually operate it by changing settings on its control panel. (See Figure 1 for reference to location of the control panel and circuit breakers on the furnace.)

FIGURE 1

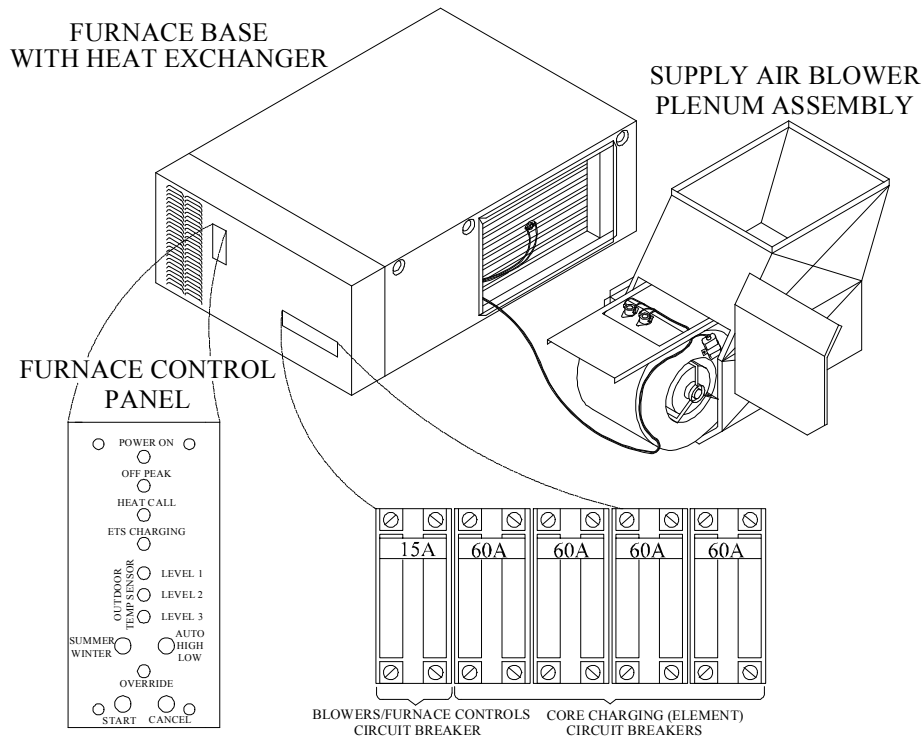

POWER ON Light

This green indicator light illuminates whenever the furnace is energized.

OFF-PEAK Light

This red indicator light illuminates during off-peak times which are the times when the furnace is allowed to charge. (Elements can be "ON" to store heat in the brick core.)

HEAT CALL Light

This yellow indicator light illuminates whenever the furnace is receiving a signal from the wall thermostat to deliver heat.

ETS CHARGING Light

This red indicator light illuminates whenever the heating elements in the furnace are "ON". (Furnace is storing heat in its brick core.)

OUTDOOR TEMP SENSOR Lights

These red indicator lights illuminate to designate the brick core charge level the furnace is targeting whenever the elements are allowed to be "ON". (Refer to Table 1, Brick Core Charging Schedule, in this manual for more information on charging levels in relation to outdoor temperature and the furnace control panel settings.)

- LEVEL 1 = Illuminates when the furnace is targeting a heat storage setting of approximately 1/3 core charge (500°F, nominal) or greater.
- LEVEL 2 = Illuminates when the furnace is targeting a heat storage setting of approximately 2/3 core charge (900°F, nominal) or greater.
- LEVEL 3 = Illuminates when the furnace is targeting its maximum heat storage setting (1350°F, nominal).



All outdoor temperature sensor lights will be illuminated when the furnace is targeting its maximum heat storage setting.

SUMMER/WINTER Toggle Switch

This toggle switch will vary core charging in the furnace. It allows for a reduced heating capacity during the summer months if the user prefers to leave the furnace "ON" for emergency heat purposes during this time. (Refer to Table 1, Brick Core Charging Schedule, in this manual for more information on charging levels in relation to the position of this switch and outdoor temperature.)

AUTO/HIGH/LOW Toggle Switch

This toggle switch can be used to override the automatic outdoor temperature sensing system.

AUTO = Normal operating position. The brick core charge level is controlled automatically by the outdoor temperature sensor.

HIGH = The furnace will target a level 3 (maximum) core charge during an off-peak time regardless of the outdoor temperature information it is receiving.

LOW = The furnace targets a minimum of a level 1(1/3) core charge during an off-peak time unless the outdoor temperature sensor is signaling for a higher charge level.

OVERRIDE Light (Power Company Permitting)

This red light illuminates whenever a peak control override is initiated and remains illuminated for the duration of the override period. The function of the override indicator light works in conjunction with START and CANCEL toggle switches.

START and CANCEL Toggle Switches (Override Feature, Power Company Permitting)

The furnace has a built-in peak override feature. This feature allows the heating elements in the furnace to come "ON" during a peak control time provided the power company permits the use of this option. Since not all power companies permit use of the override option, all furnaces are shipped with this feature disabled. If the feature is enabled in the furnace, these toggle switches initiate and cancel the override of a peak control time.

START = Initiates an override of a peak control time allowing the heating elements to come "ON". The furnace targets a level 1 (1/3) core charge during an override cycle. If initiating the peak control override feature, the override will only last for the duration of the peak control period at which time it resets itself automatically unless the user manually cancels it prior to then. (The override light will illuminate if the START switch is toggled.)

CANCEL = Allows for manual cancellation of a peak override any time during an override cycle. An override cycle will automatically cancel itself at the start of the next off-peak period.



The peak override option may not be available in your area. Please consult your power company if you are unsure of whether this option is available to you. If so and you desire to enable the feature, contact your power company for instructions.

1 FURNACE START-UP

On start-up of the furnace, you may experience some odors relating to first time operation of the heating components. There may also be an odor associated with dust accumulation in the system if the furnace is shut-down for an extended period of time. Upon restart, allowing the furnace to charge to its maximum brick core charge level will help expel these odors in a timely manner.

During operation, it is normal for the furnace, like any heating system, to produce expansion noises. These noises are the result of the internal components reacting to the temperature changes they are exposed to.

2 ROOM TEMPERATURE CONTROL

Room temperature is adjusted at the wall thermostat. With a heat call to the thermostat, the core blower in the furnace is energized to circulate hot brick core air through the furnace's heat exchanger. The core blower automatically adjusts its' speed (low or high) in relation to the brick core temperature. The blower operates in low speed with a hot brick core and in high speed with lower brick core temperatures.

After the brick core air warms the heat exchanger, the supply air blower is energized. The supply air blower circulates the room air through the heat exchanger to warm it; and, then, delivers it back into the living space through the duct system.

The delay between the core blower operating and the supply air blower being energized ensures only warm, comfortable, even heat is being delivered into the living area. Intermittent supply air blower operation may occur with lower brick core temperatures in an effort to maintain a constant temperature and even distribution of heat into the living area.

Some thermostats incorporate a room temperature set back feature which allows for room temperature to automatically be set back a specific number of degrees at specified times. If using a thermostat with this feature in a program where the power company has 8 or more consecutive hours of control, it is important to bring the room temperature back to the desired occupied temperature a minimum of three (3) hours before the off-peak (charge) period ends. This will ensure optimum heat storage for maintaining the desired room temperature throughout the on-peak (control) period.

3 BRICK TEMPERATURE CONTROL (CORE CHARGING)

The amount of heat stored in the brick core of the furnace is regulated automatically in relation to outdoor temperature and to its control panel settings. The outdoor temperature sensor that ships with the furnace as standard equipment **MUST** be mounted outside. It provides temperature information to the furnace for proper brick core charging.

In standard configuration from the factory, the outdoor sensor signals the furnace to maintain a level 1 (1/3) brick core charge at a 55°F outside temperature, a level 2 (2/3) core charge at 35°F, and a level 3 (maximum) core charge at 15°F. At temperatures above 55°F, the furnace will not maintain a core charge; however, if there is a heat call from the thermostat during off-peak times, 1/3 of the elements will be energized to provide heat for the duration of the heat call. (Refer to Table 1, Brick Core Charging Schedule, for more information on charging levels in relation to outdoor temperature and the furnace control panel settings.)



If outdoor temperature charging set points other than the standard configuration are preferred, the sensor must be specially ordered from the factory.

BRICK CORE CHARGING SCHEDULE

Table 1

During brick core charging, the heating elements are staged "ON" and "OFF" in 6.4kW increments (maximum).

SUMMER/WINTER SWITCH POSITION	OUTDOOR AIR TEMP. (°F)	CHARGE LEVEL	kW INPUT (MAX)		CORE TEMP. °F (Nominal)
			DLF30B	DLF40B	
Winter	55*	1	9.6	12.8	500
Winter	35	2	19.2	25.6	900
Winter	15	3	28.8	38.4	1,350
Summer	35	1	9.6	12.8	500
Summer	15	3	28.8	38.4	1,350

* If during off-peak hours the wall thermostat calls for heat and the outdoor temperature is above 55°F, 1/3 of the elements will be energized for the duration of the heat call.

The AUTO/HIGH/LOW toggle switch on the furnace control panel will allow the user to override the automatic charge control system of the furnace. In normal operation, this switch is set to the AUTO position. Regardless of the position of this switch, the brick core charging system in the furnace is designed to respond to the coldest temperature signal it is receiving. As a result, if the toggle switch is set to LOW and the outdoor sensor is calling for a higher brick core temperature setting, the furnace will respond to the sensor signal. Or, should the charge level 1 sensor fail to respond to outdoor temperature, the charge level 2 or 3 sensors will initiate core charging. This feature provides control redundancy which reduces the chance of having an uncharged or undercharged brick core during cold weather.

4 HOW TO TURN THE FURNACE "OFF" AND "ON"

Since heat calls are unlikely during the summer months, you may wish to turn the furnace "OFF". To do so, switch all 60 amp core charging breakers located on the front of the furnace's electrical panel to the "OFF" (down) position. (See Figure 1 for reference to the location of the breakers on the furnace.) The 15 amp breaker should remain "ON" at all times as this breaker operates the blowers and all other controls in the furnace. It MUST remain "ON" if using the furnace in conjunction with an air conditioning system. To turn the furnace "ON", switch the breakers to the UP position.

For users who prefer to maintain a reduced heating capacity during summer months rather than shutting the system off completely, the SUMMER/WINTER toggle switch should be set to the SUMMER position. In standard configuration, a SUMMER switch setting enables automatic brick core charging but at a reduced level. The outside temperature must drop below 35°F before core charging will occur. (Refer to Table 2, Brick Core Charging Schedule, in this manual for more information on charging levels in relation to outdoor temperature and the furnace control panel settings.)

1 SHIPPING

The furnace is shipped disassembled for ease in handling and moving into location where it is to be installed. (Refer to Table 2 for information on the items shipped with each furnace.)

Table 2

MODEL (See Note 1)	BRICK (See Note 2)	ELEMENTS (See Note 3)	DUCTING
DLF30B	28 boxes Whole Brick (3/Box) 2 boxes Half Brick (6/Box)	9	1 Box Return Air Filter Rack 1 Box Supply Air Blower Plenum Assembly 1 Hardware Package (See Note 4)
DLF40B	37 boxes Whole Brick (3/Box) 2 boxes Half Brick (6/Box)	12	1 Outdoor Temperature Sensor (See Note 5)

- NOTES: 1. The furnace ships in two sections (brick storage cavity and base assembly) banded to one pallet.
 2. Each brick box weighs approximately 72 lbs each.
 3. The elements are shipped inside the brick storage cabinet of the furnace.
 4. The hardware package is shipped in the base assembly portion of the furnace.
 5. The outdoor temperature sensor is shipped in the supply air blower plenum assembly box.

2 PLACEMENT

The physical dimensions of the furnace along with the clearances required must be taken into consideration when choosing a location for the furnace. The minimum area needed for the installation of a furnace is 100 square feet. The best installation location for the furnace is in an area it will be heating. Although most of the heating requirements of the space will be satisfied by the heat delivered through the duct system, a small amount of the heating requirements will also be satisfied through static heat dissipating through the furnace's warm outside panels. In situations where the furnace will not be installed in the area it is intended to heat (i.e. garage), it is important to account for the heat lost through its panels by making proper adjustments in sizing of the furnace.

In addition to the physical space requirements, the weight of the furnace must also be taken into consideration when selecting the installation surface. A level concrete floor is the best surface on which to place the furnace, but most well supported surfaces are acceptable. If in doubt about floor load capacity, consult a building contractor or architect. (See Figure 2 for furnace and ducting dimensions.)

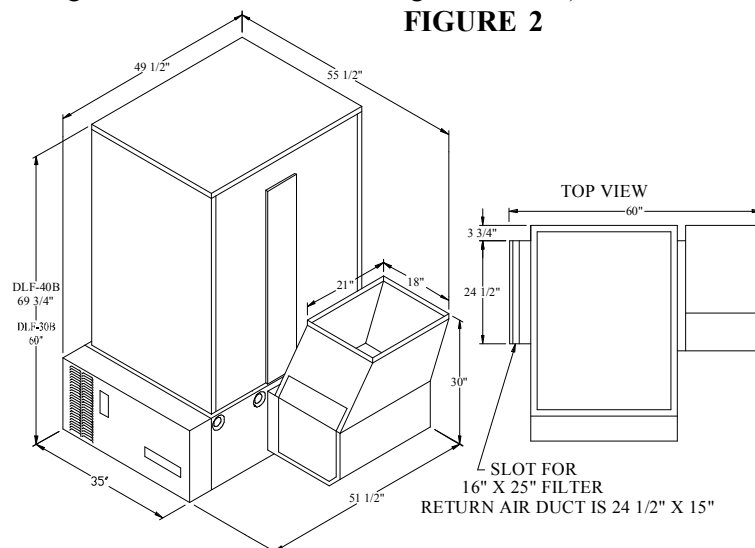

3 CLEARANCE REQUIREMENTS

The minimum clearances required when installing the furnace into any area are as follows:

- Back and Sides = 3 inches (from combustible material)
- Top = 6 inches (from combustible material)
- Front = 36 inches (for ease of servicing)
- Furnace Right Side and Air Duct = 2 inches
- Furnace Left Side and Air Duct = zero clearance
- Sides of Furnace Ducts = zero clearance

The clearance areas must be kept open and free of debris. Do not place anything on top of the furnace. If the furnace is installed in a small, enclosed area (less than 400 square feet), the area must be well ventilated. For ventilation purposes, a minimum of a 24" X 24" opening must be installed, if not already present, into the area where the furnace is located. In addition, a 6" X 6" non-closing type register must be cut into the return air duct of the furnace to minimize heat build-up in the room. (See Figure 3 for a depiction of clearance specifications.)

4 FURNACE SET-UP



For cross reference to number coded components, see the Exploded View Diagram and the Furnace Parts List in this manual. Refer to Table 2 in the Shipping section of this manual for a list of items each furnace should contain.

- Step 1** Unbox the brick storage cabinet
- Step 2** Remove painted front panel (11) of cabinet by removing the sheet metal screws on the lower edge. Rotate bottom edge of panel out to detach it from the cabinet.
- Step 3** On the right side of the cabinet, remove the screws around the limit bar louvre panel (63). (See Figure 4 for reference to the location of this panel and the screws.)
- Step 4** Slide the sides and back painted outer panels (9, 71, & 73) backwards as one assembly and remove from cabinet.
- Step 5** Use the handles on the brick storage cabinet to move it to its installation location. Set aside for now.



Removal of the limit switches (67) on the right side of the brick storage cabinet may be necessary to avoid damage to these switches during the move.

- Step 6** Remove the base assembly (50) from its box and move it to the installation location. Discard the wooden packaging from the top of the base. Locate and set aside the hardware package shipped on top of the base assembly.



Do NOT install the furnace on its shipping pallet.

FIGURE 3

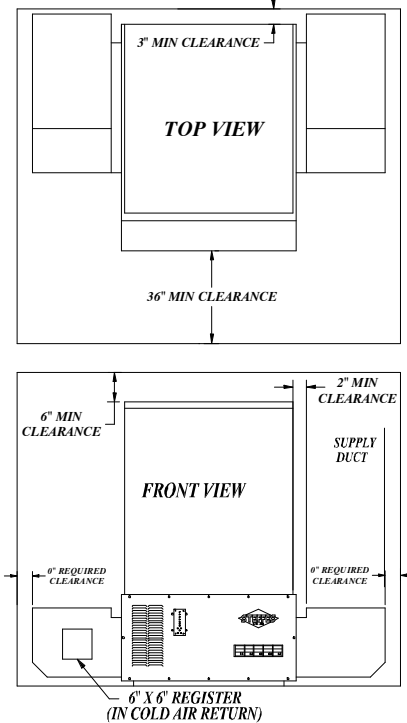
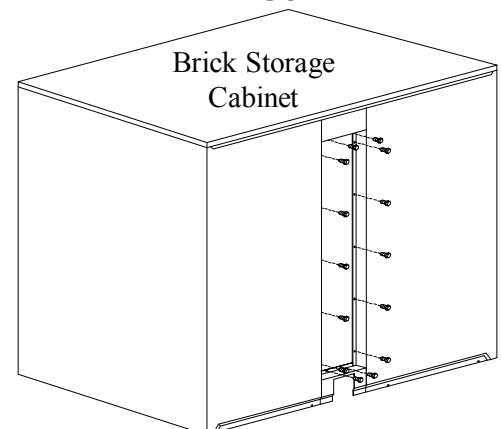

FIGURE 4



Step 7 Adjust the leveling legs (48) on the bottom of the base assembly (50) once it is set in final position.



The leveling legs must not be extended more than one inch. The base **MUST** set securely on all four legs to prevent rocking of the furnace and/or twisting of the heat exchanger.

Step 8 Set the brick storage cabinet on the base assembly (50) taking care not to damage the wiring harnesses (65 & 70).



The rope gasket around the heat exchanger inlet and outlet of the base assembly must be properly adhered and free from damage. Damage to any gasketing on the furnace will result in improper unit operation and/or furnace damage.

Step 9 Position wiring harnesses (65 & 70), and temperature sensing bulb and plate assembly (77) to facilitate routing through bottom right side panel cutout. (See Figure 5 for reference to wiring harness locations on the furnace.)

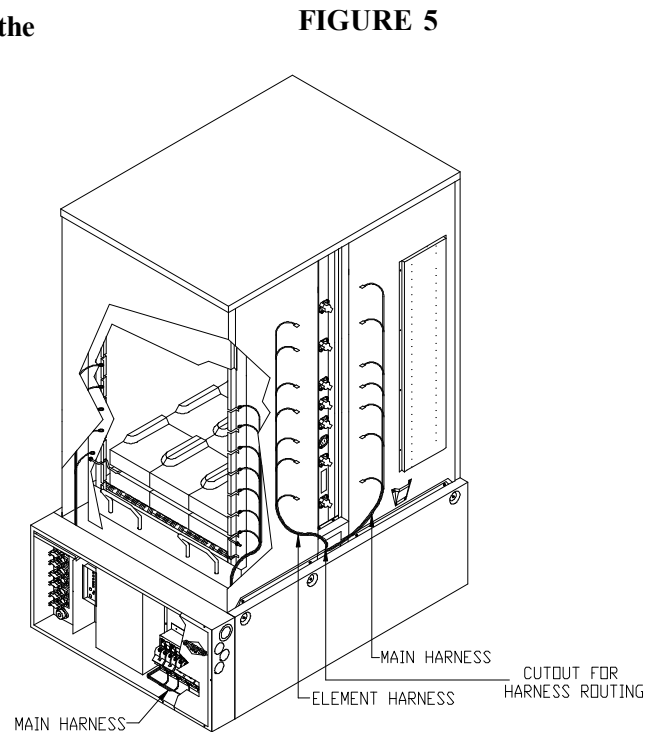

Step 10 Install the sides and back painted outer panels (9, 71 & 73) on the brick storage cavity. Use the screws found in the hardware package to secure the panels to the cabinet by placing them along bottom edge of the panels.



To avoid internal wire damage, use only blunt tip screws in all areas where screw tips could come in contact with wiring.

Step 11 Install the temperature sensing bulb and plate assembly (77) by tightening the screws in a cross pattern until gasket is compressed. Do not overtighten. Make certain that the capillary tube of the temperature sensing assembly (77) does not come into contact with any live electrical terminals.



Failure to seal the sensing bulb plate will cause abnormal furnace operation and potential component damage.

Step 12 Connect the main and element wiring harnesses (65 & 70) to the limit switches (67). The switches are marked with a red dot on one side. Connect the red wires to the red dot marked side of the switches. Connect the black wires to the unmarked side of the switches.

- Step 13** Connect the brown thermocouple lead wire (79) in the wiring harnesses to the core temperature sensor (68). The yellow wire of the thermocouple lead attaches to the screw stud marked with a yellow dot. The red wire attaches to the screw stud marked with a red dot.



The brown thermocouple lead wire must be routed in a fashion that ensures it will be protected from physical damage and does not come into contact with any live electrical connections in the limit bar area. Incorrect polarity on the core temperature sensor will cause the furnace to continue to charge, even when a high charge level has been achieved.

- Step 14** Carefully install the limit bar channeling plate (61) to provide air seal around wiring harnesses (65 & 70).

- Step 15** Install the limit bar louvre panel (63).

5 BRICK LOADING

- Step 1** Remove the sheet metal screws around the outer edge of the galvanized front panel (12) and set the panel aside.

- Step 2** Carefully lift the three insulation blankets (3, 4, & 5), one at a time, and drape them over the top of the furnace.



Use face mask, gloves, and long sleeved garments when handling insulation materials in accordance with generally accepted safety practices.

- Step 3** Remove the aluminized steel panel (10) by pulling out at the top.

- Step 4** Remove the heating elements (17) and the packing material from the brick core cavity. To ensure adequate room for brick loading, the top or bottom 1" x 4" (nominal) wooden core spacer can be used to hold inner brick cavity walls apart.



The core spacer is packaging material and can be discarded after brick loading is complete.

- Step 5** To minimize the amount of brick debris falling into the core blower, place the cardboard packaging material found inside the brick cavity over the core blower opening.

- Step 6** Load the brick (15), one row at a time, starting at the back working forward. Below is a list of installation tips to aid in the brick loading process:

FIGURE 6

- Be sure to remove loose brick debris as the furnace is being loaded to prevent uneven stacking of the bricks.

- Use the half brick (boxes marked) in the proper rows and in the correct positions. The half bricks should be loaded in rows 4 and 8 in th DLF30 and in rows 5 and 10 for the DLF40, with row 1 being at the bottom. (See Figure 6 for the correct position of the half bricks.)

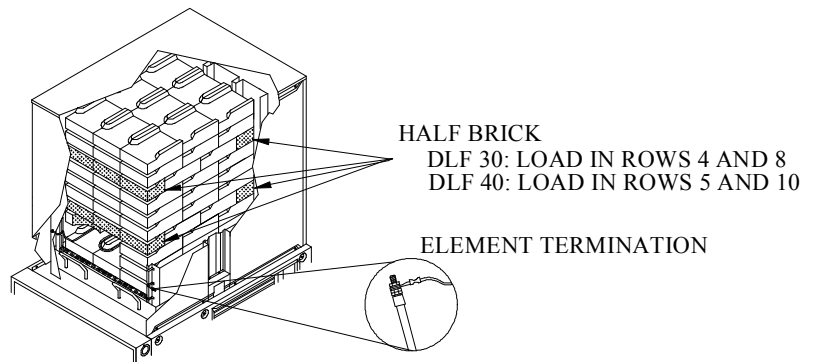

The purpose of the half brick is to make brick loading easier by evening out the stacking. From an operation perspective, it is not essential they be placed in the rows recommended for each model. The rows recommended simply make for the best fit.

FIGURE 7

- The second to last row, front, middle brick must be the last brick installed. A shim may be used to hold the upper brick in place, or it is more easily accomplished by leaving the middle brick in the second to last row pulled about 4" forward from its intended position. In this position the brick will act as a support for the top middle brick. Push the front, middle brick in the second to last row into place which will at the same time push the middle brick that was left forward into place. (See Figure 7 for a picture depiction of this procedure.)

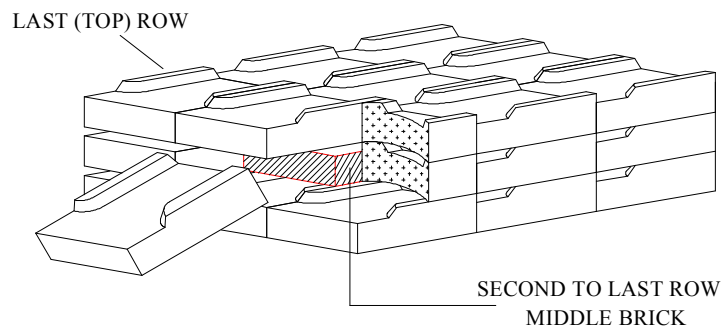

6 INSTALLING THE HEATING ELEMENTS

Step 1 After all bricks are loaded, insert the heating elements (17) between the brick layers with the cold pins facing up. (See picture depiction of element termination in Figure 6 for reference to cold pin direction.)

Step 2 Make the heating elements (17) to wiring harness (19 & 65) connections. (See Figure 6 for a picture depiction of element termination.)



Use two 3/8" wrenches to ensure tight connections and to avoid twisting the threaded element cold pins off.

Step 3 Replace the front aluminized steel panel (10).



This panel **MUST** be installed with its air deflectors (arrow shaped pieces) facing inward and with the narrow ends of the deflectors pointing up.

Step 4 Lower the insulation blankets (3, 4, & 5) back into position, one at a time. Carefully tuck the sides of this insulation into the edges, corners, and around the exposed portions of heating elements (17).

Step 5 Replace the galvanized front panel utilizing the original #8 x 1" sheet metal screws that were removed.

Step 6 Replace the painted front panel (11) using blunt tip screws only.

7 DUCTING

Air Flow

The Steffes furnace has been specially designed for versatility and may be installed to meet right-to-left or left-to-right air flow requirements. The furnace is factory configured for a left-to-right air flow. If it is desired to reverse the air flow, do the following:

Step 1 Reroute the supply air blower wiring harness (55) to the opposite side of furnace base by fishing the harness between bottom radiant heat shield (51) and bottom panel (47). Be sure to route the wiring harness away from the heat exchanger and place any excess wiring between the radiant heat shield (51) and bottom panel (47).

For air delivery, the furnace is equipped with a 4-speed supply air blower which is factory wired to operate in medium low speed for heating and in medium high speed for cooling and a fan only thermostat setting. The blower speed may be adjusted for lower or higher output requirements. To do so, change the wiring on the blower speed selection terminals located on the supply air blower. (See the Line Voltage Wiring Diagrams in this manual for more information on the wiring and Table 3 for information on duct pressure with regard to blower speed.)

TABLE 3

SUPPLY AIR BLOWER SPEED	STATIC PRESSURE (INCHES WATER)		
	0.10	0.25	0.50
HIGH	Not Recommended	1850 CFM	1560 CFM
MEDIUM HIGH	1800 CFM	1780 CFM	1470 CFM
MEDIUM LOW	1610 CFM	1580 CFM	1420 CFM
LOW	1230 CFM	1205 CFM (.20 Static Maximum)	Not recommended

Attaching the Ducting

- Step 1** Remove the supply air blower plenum assembly (60) and filter rack (18) from their boxes.
- Step 2** To access the blower (56), remove the screws from the supply air blower plenum front access cover (60) and detach it from the plenum.
- Step 3** The supply air blower (56) is shipped banded to the plenum assembly (60). Cut the band to remove the blower from the plenum and slide it into the plenum track through the front access.
- Step 4** Attach the front access cover to the plenum.
- Step 5** Attach the supply air blower plenum assembly (60) to the furnace by drilling two 1/8" holes per edge. Attach to the furnace supply air side using the blunt tip screws supplied in the hardware package.
- Step 6** Secure the filter rack assembly (18) on the return air side, again by drilling 1/8" holes per edge and using the blunt tip screws supplied in the hardware package. A filter should already be included and installed in the duct slot of the filter rack assembly.
- Step 7** Connect both the return air and supply air house ducts to the furnace.



If the furnace is installed in a small enclosed area, a minimum of a 24" x 24" opening into the area where the furnace is located must be installed if not already present. In addition, a 6" x 6" non-closing type register must be cut into the return air duct. (Refer to the Clearance Requirements section of this manual for more information.)

8 LINE VOLTAGE ELECTRICAL CONNECTIONS

In standard configuration, the furnace is wired for connection to 240V but are available with 208V or 277V heating elements as special factory orders. However, the blowers and furnace controls circuit must always be connected to 240V or 208V.

The furnace is set up for multiple feed circuits. The 60 amp breakers located in the electrical compartment at the base of the furnace feed the core charging (element) circuits. The 15 amp breaker feeds the furnace controls and blowers circuit. The furnace's elements and blowers/controls circuit can be fed with separate circuits or the blowers/controls can be fed from one of the element circuits. If single feed of the charging (element) circuits is desired, an optional single feed kit is available from the factory. (Order item #1309000.) The single feed kit enables the furnace to be fed with a single circuit which then splits this circuit internally to each breaker.

NOTE All line voltage circuits must be segregated from low voltage wiring in the furnace.

To determine the correct wire size required for each circuit feeding the furnace, refer to the Unit Specifications section in this manual. It is the responsibility of the installer to follow all applicable electrical codes and regulations for the installation.

- Step 1** Remove the electrical panel cover (46).
- Step 2** Route line voltage wiring through a knockout and into the electrical panel of the furnace.
- Step 3** Make the proper field wiring connections to the furnace breakers. (See the Line Voltage Wiring Diagrams in this manual for more information on these connections.)

NOTE To reduce magnetic fields that can be produced by electrical circuits, it is recommended to alternate the circuit phases in the furnace. (See Figure 8 for more information on how to phase connect the circuits.)

FIGURE 8

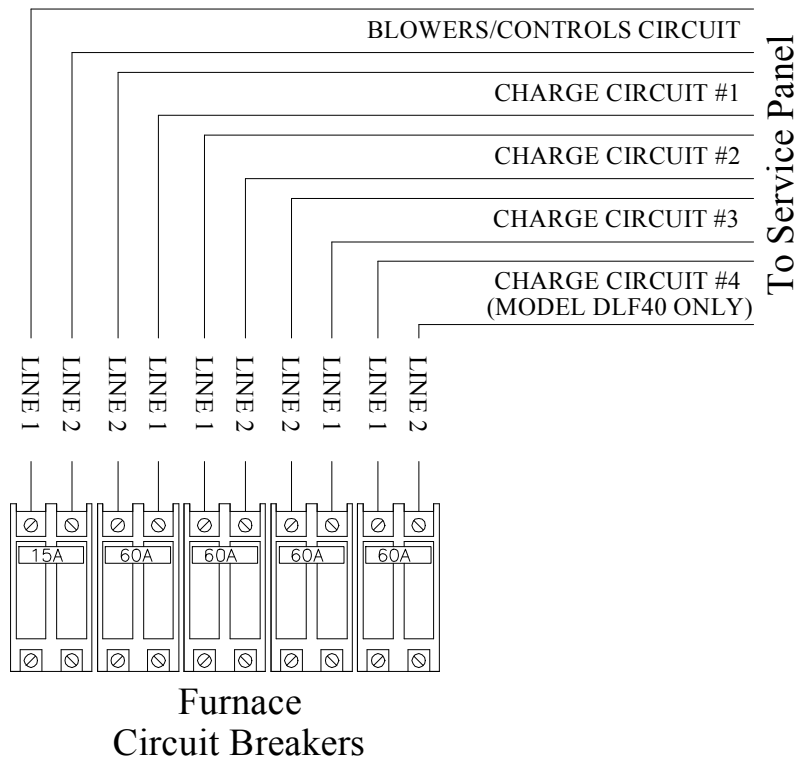

Line Voltage Wiring Diagrams

DLF30B - 240V OR 208V UNITS ONLY

FIGURE 9



Use copper or aluminum conductors rated for 75C or higher for field connection of this device.

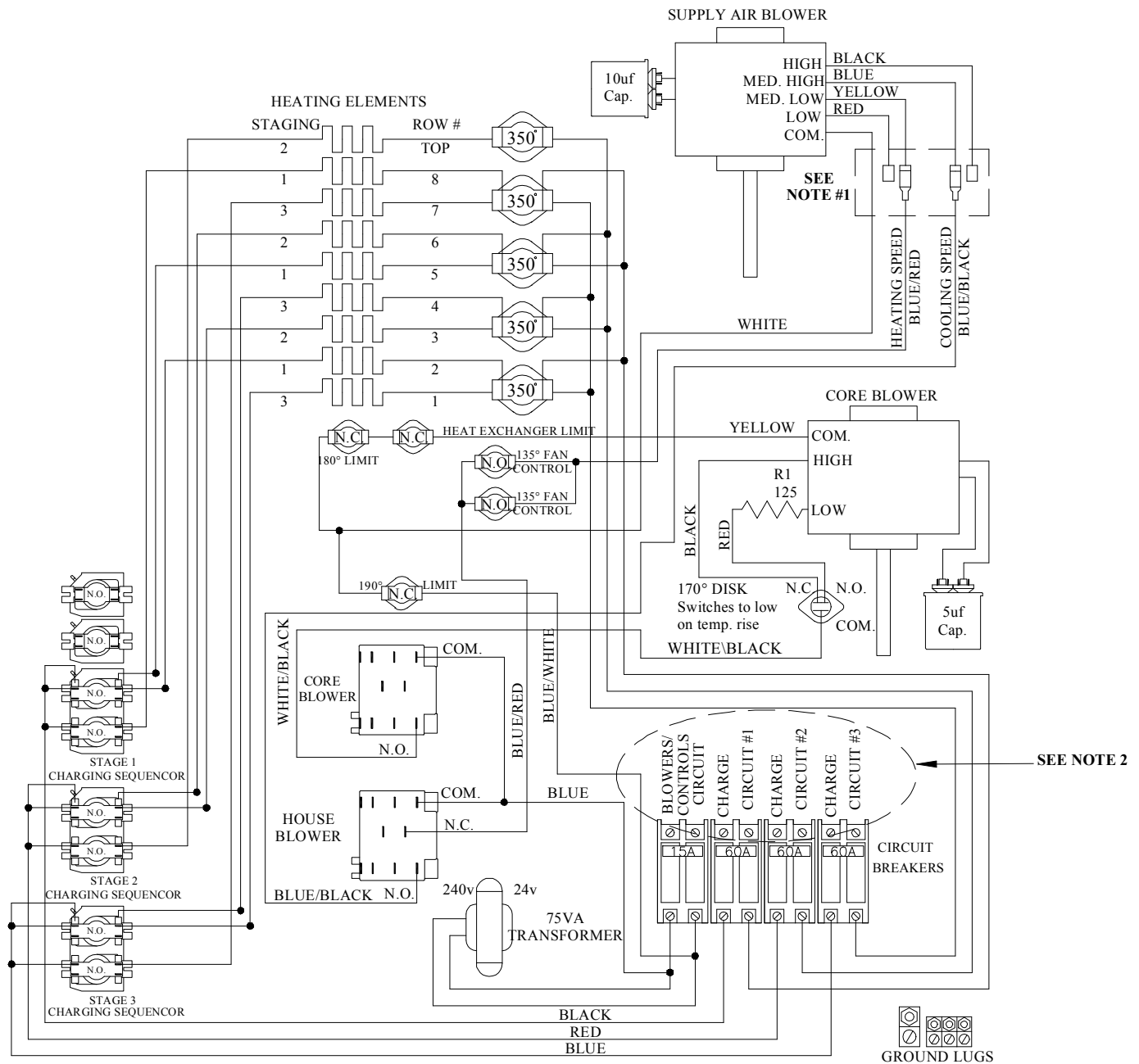

- NOTES:**
1. Supply air blower speed selection terminals wiring.
 2. Line voltage field wiring connections, (see Figure 8).

Installing The Furnace (cont'd)

DLF40B - 240V OR 208V UNITS ONLY

FIGURE 10



Use copper or aluminum conductors rated for 75C or higher for field connection of this device.

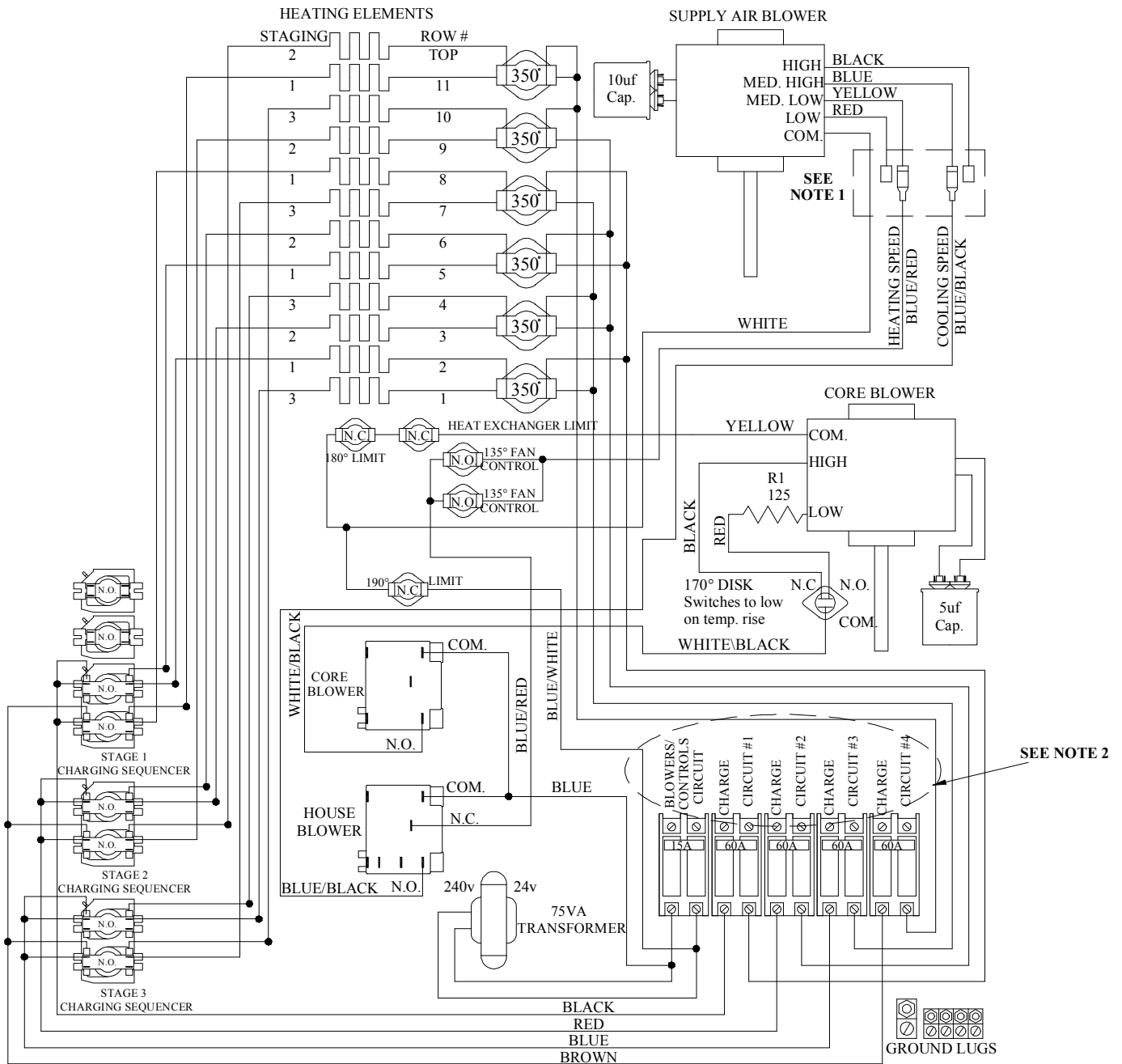

- NOTES: 1. Supply air blower speed selection terminals wiring.
 2. Line voltage field wiring connections, (see Figure 8).

DLF30B AND DLF40B - 277V UNITS ONLY

FIGURE 11



Use copper or aluminum conductors rated for 75C or higher for field connection of this device. The blowers and the controls circuit **MUST** be powered with 240V or 208V.

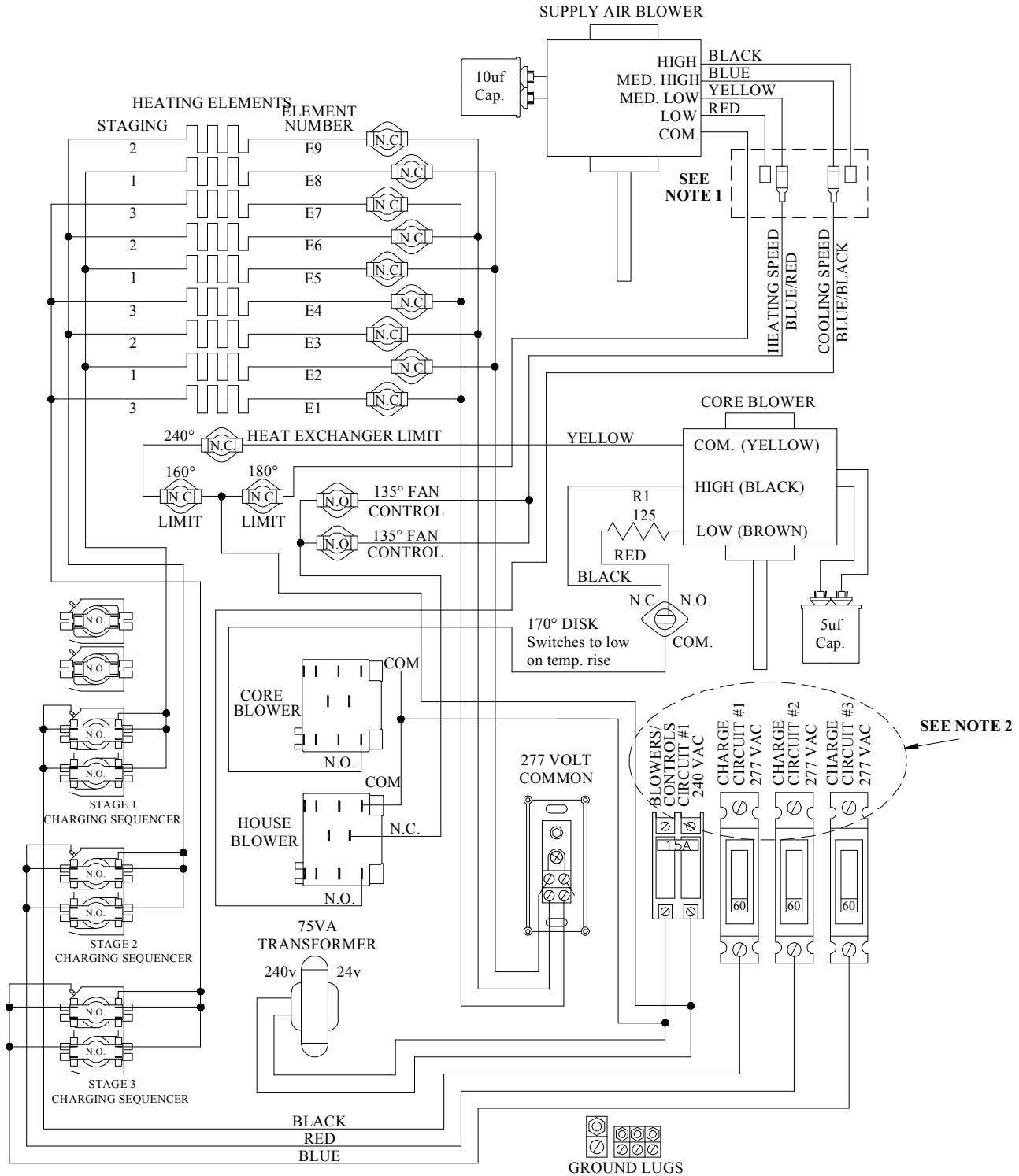

- NOTES:** 1. Supply air blower speed selection terminals wiring.
 2. Line voltage field wiring connections, (see Figure 8).

9 LOW VOLTAGE ELECTRICAL CONNECTIONS

The outdoor temperature sensor, room thermostat, and peak control signal are low voltage wire connections to the furnace. All low voltage wiring must be segregated from line voltage circuits in the furnace.

Low Voltage Wiring Diagram

FIGURE 12

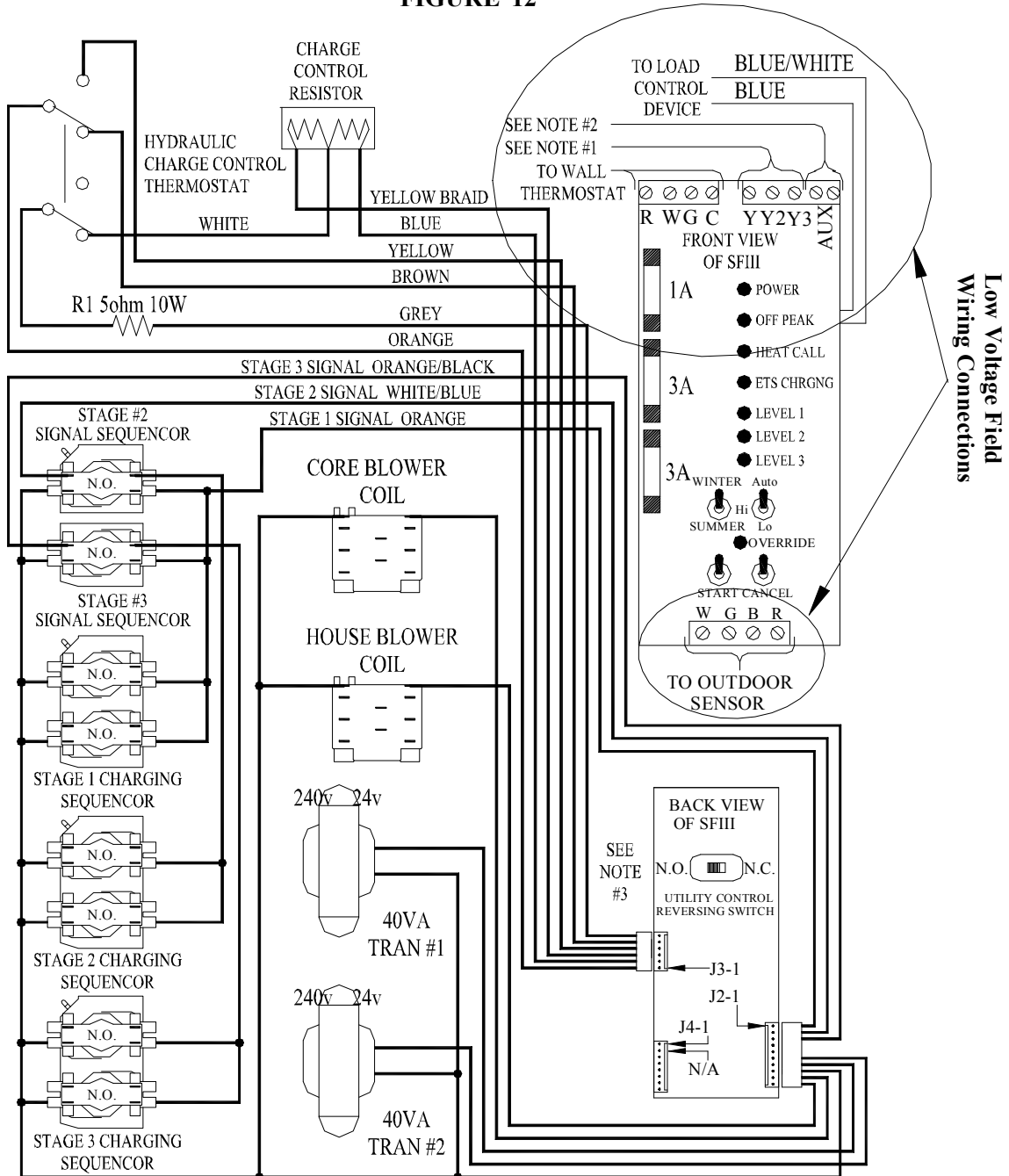

Low Voltage Field Wiring Connections

NOTES:

1. Low voltage auxiliary control contacts.
 - a. Y to Y2 contacts open when load control device closes.
 - b. Y to Y3 contacts close when load control device closes.
2. Auxiliary contacts close during off-peak heat calls.
3. N.O. used for open on-peak load control device (switch closes to charge).
N.C. used for closed on-peak load control device (switch opens to charge).

Outdoor Temperature Sensor

The outdoor temperature sensor provides outdoor temperature information for automatic charge regulation of the furnace. In standard configuration from the factory, the outdoor sensor is calibrated at 55°F, 35°F, and 15°F for initiating the level, 1 (1/3), 2 (2/3) and 3 (maximum) brick core charges. If outdoor temperature charging set points other than the standard configuration are preferred, the sensor must be specially ordered from the factory.

Outdoor Sensor Placement:

The outdoor sensor is shipped inside the supply air blower plenum assembly. When installing the sensor, please follow these recommended guidelines in relation to placement and wiring:

- Optimal placement of the outdoor temperature sensor is on an outdoor surface in a location above ground level where it will not be affected by direct sunlight or other sources of heat or cold.
- The outdoor sensor has an 8-foot, 4-conductor, 300V insulated cable (18AWG). If this is not long enough for the installation, additional wire can be spliced to this wire. Since this is a low voltage circuit, standard Class II (thermostat) wire can be used as extension wire provided it does not enter the line voltage areas of the furnace.

Outdoor Sensor Mounting and Wiring Connections:

- Step 1** Attach the outdoor temperature sensor (64) to an outdoor surface using its four mounting flanges.
- Step 2** Disconnect power to the furnace and route the low voltage wire from the sensor to the furnace.
- Step 3** Route the wire into the furnace's electrical compartment and up to the charge control circuit board (30).



Never install any wiring in the line voltage compartment of the furnace unless it is rated for line voltage.

- Step 4** Connect the sensor to the 4 position terminal strip on the bottom front of the charge control circuit board (30). The wire is color coded to match the terminal position in which it should be connected: White (W), Green (G), Black (B), and Red (R). (See the Low Voltage Wiring Diagram in this manual for a depiction of the location of these terminals.)

Room Thermostat

A low voltage thermostat is required for room temperature control with the furnace. Steffes has both mechanical and digital configurations with a heating and cooling sub base available for use with this system. Some also provide a room temperature set back option. Any thermostat used with this system must be 24 VAC and have the ability to switch 1/2 amp minimum at a .5 anticipator setting. (Contact the factory for more information on the thermostats available from Steffes.)

In applications where an air conditioning system will be used in conjunction with the furnace, the furnace can also be used to control the air conditioning system through the wall thermostat during the cooling months. (See Figure 13 for information as to how to make room thermostat connections.)

Placement:

Optimal placement of the room thermostat is on an interior wall where it will not be affected by direct sunlight or other sources of heat or cold.

Mounting and Wiring Connections:

- Step 1** Attach the thermostat to a wall. Insulate the opening through which the thermostat wires runs. Failure to do so may affect the accuracy of the thermostat.
- Step 2** Disconnect power to the furnace and route low voltage wire between the thermostat and the furnace.
- Step 3** Route the wire into the furnace's electrical compartment and to the front of the charge control circuit board (30).



NOTE Never install any wiring in the line voltage compartment of the furnace unless it is rated for line voltage.

- Step 4** Connect the thermostat to the 4 position terminal strip on the top front left corner of the charge control circuit board (30) labeled “R”, “W”, “G”, and “C”. (See Figure 13 for reference to room thermostat connections to the furnace.)
- Step 5** If the thermostat has an anticipator, set it to .5 amps.

FIGURE 13

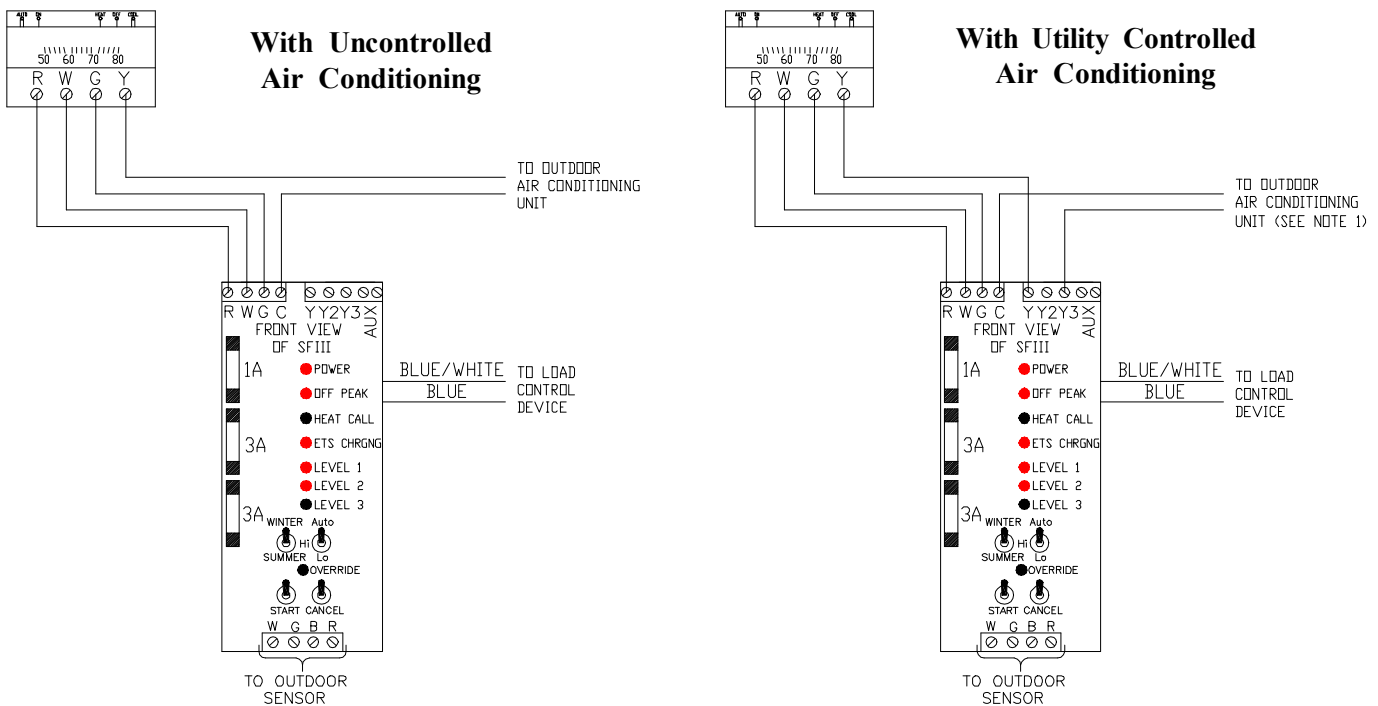

NOTES: 1. Wiring shown is for use with N.O. (switch closes to charge) load control device. Y and Y2 would be used with a N.C. system (switch opens to charge).

Peak Control

The heating elements in the furnace are controlled on-peak (not able to store heat in the brick core) via low voltage wiring.

Connecting the furnace to load control signaling device:

Step 1 Route a low voltage circuit from the power company's load control peak signaling device to the charge control circuit board (30) located inside the electrical compartment of the furnace.



Never install any wiring in the line voltage compartment of the furnace unless it is rated for line voltage.

Step 2 Connect the field wiring to the BLUE and BLUE/WHITE wires hanging from the back of the charge control circuit board (30). (See to the Low Voltage Wiring Diagram in this manual for a depiction of the location of these wires.)

Step 3 Be sure the "N.O./N.C." slide switch on the back of the charge control circuit board (30) is in the position that matches the input of the power company's load control signaling device.

N.O. = A closed power company switch will signal an off-peak time to the furnace (charging is enabled). An open power company switch will signal an on-peak time to the furnace (charging is disabled).

N.C. = An open power company switch will signal an off-peak time to the furnace (charging is enabled). A closed power company switch will signal an on-peak time to the furnace (charging is disabled).

Optional Features



These recommended wiring methods reflect only devices that accept a remote low voltage power source. Refer to the specific installation instructions for the device before making any connections to the furnace.

Control of Other Loads:

The furnace can be used to control other loads in the application. To do so, connect the other loads using low voltage wire to the "Y" positions of the terminal block located on the upper right front corner of the charge control circuit board. (See the Low Voltage Diagram in the manual for reference to these terminal block positions.)

Connecting a Humidifier:

Figure 14 shows the general concept for connecting a humidifier to the furnace. Refer to installation instructions of the humidifier prior to making any connections.

Connecting an Electronic Air Filter:

Figure 15 shows the general concept for connecting an electronic air filter to the furnace. Refer to installation instructions of the filter prior to making any connections.

FIGURE 14

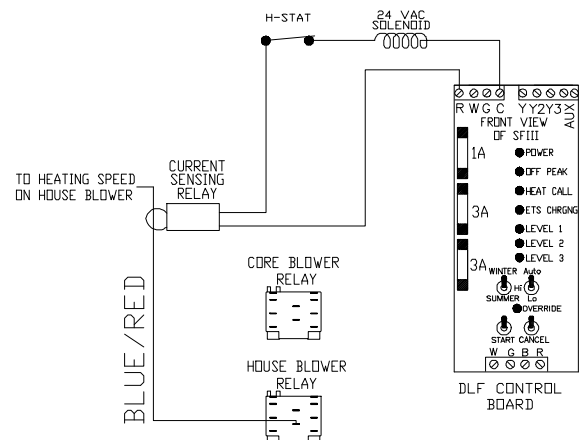
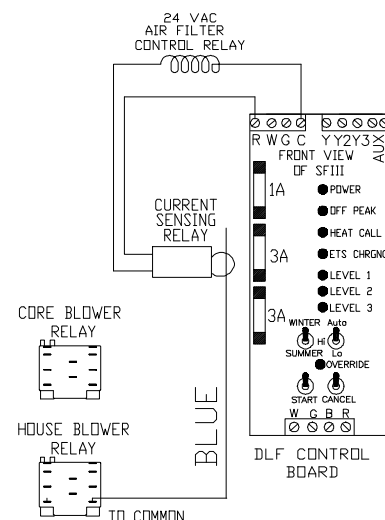

FIGURE 15



9 FURNACE FINAL TEST PROCEDURE

- ___ 1. Check all electrical connections for proper termination placement and do a general inspection for tight connections, wire routing, etc.
- ___ 2. Energize the furnace.
- ___ 3. If the wall thermostat has an anticipator, set the anticipator 0.5 amps.
- ___ 4. Turn up wall thermostat to bring on a call for heat. Core blower (38) should run on its high speed with a cold brick core. Because the brick core is cold, the supply air blower (58) will not run in this mode.
- ___ 5. If the thermostat is equipped with a mode selection switch, set to FAN ONLY, and check for medium high speed (cooling) supply blower (58) operation.



See Figure 16 for switch positions to complete steps 6, 7, and 8.)

- ___ 6. In the off-peak mode and with the outdoor air sensor (64) disconnected, jumper sensor connection terminals "W" & "R" of the charge control circuit board (30) together to perform the following tests:
 - ___ A. Set selector switches to SUMMER and AUTO positions. One outdoor sensor light should be on. Check the unit's charging circuits amperages. On 240V systems, they should read:
DLF30B = 40 Amp DLF40B = 53 Amp
 - ___ B. Set selector switches to WINTER and AUTO positions. Two outdoor sensor lights should be on. Check the unit's charging circuits amperages. On 240V systems, they should read:
DLF30B = 80 Amp DLF40B = 106 Amp
 - ___ C. Set selector switches to WINTER and HIGH position. Three outdoor sensor lights should be on. Check the unit's charging circuits amperages. On 240V systems, they should read:
DLF30B = 120 Amp DLF40B = 160 Amp
 - ___ D. Simulate an on-peak period by changing the status of the blue and blue/white wires. All heating elements (17) should cycle off.

FIGURE 16

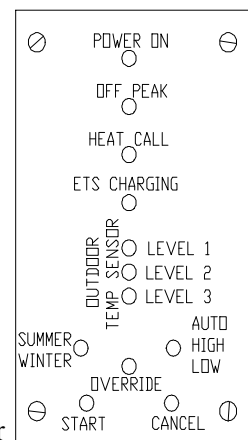

To perform Step 7, the peak override feature must be enabled. This feature may not be available in your area. Please consult your power company if you are unsure of whether this option is available to you. If it is available and you desire to enable the feature, contact your power company for instructions on how to do so. Skip Step 7 if the peak override feature is not available to you.

- ___ 7. With unit in the on-peak mode, depress the override "START" switch and observe the "OVERRIDE" indicator light. The light should be illuminated.
- ___ 8. Remove the jumper between the "W" and "R" outdoor sensor connection terminals and reconnect the outdoor air temperature sensor (64). Set the selector switches to the AUTO and WINTER positions.
- ___ 9. Replace the electrical panel cover (46), make certain all fuses and/or circuit breakers are labeled in the service panel.
- ___ 10. Present owner with the manual and warranty information. The owner's registration card must be completed and returned to Steffes Corporation to ensure warranty coverage. The owner should retain the top portion of the card for their records.
- ___ 11. Take the time needed to instruct the owner on how to operate the system.

MODEL	DLF30B	DLF40B
Charging Circuit Service Entrance For 240V Systems	3 – 50 Amp circuits (120AmpX1.25=150Amp)	4 – 50 Amp circuits (160AmpX1.25=200Amp)
Max Blower Load	6 Amps (240V systems)	6 Amps (240V systems)
Charging Input	28.8 kW	38.4 kW
Element Voltage	240V (std), 208V & 277V (opt)	240V (std), 208V & 277V (opt)
Blowers and Furnace Controls Voltage	240V (std), 208V (opt)	240V (std), 208V (opt)
Storage Capacity		
kWh	180	240
BTU	614,160	818,880
Furnace Dimensions		
Height	60"	69 ¾"
Width (without ducting)	35"	35"
Depth	49 ½"	49 ½"
Air Duct Dimensions		
Supply Air Duct (W X D opening)	18" X 21"	18" X 21"
Return Air Duct (H X D) opening)	15" X 24"	15" X 24"
Furnace Weight (approximate)	590 lbs	642 lbs
Brick Weight (approximate)	2160 lbs	2808 lbs
Installed Weight (approximate)	2750 lbs	3450 lbs
Number of Bricks		
Whole Brick	84 (28 boxes)	111 (37 boxes)
Half Brick	12 (2 boxes)	12 (2 boxes)

Exploded View Parts Diagram

FIGURE 17

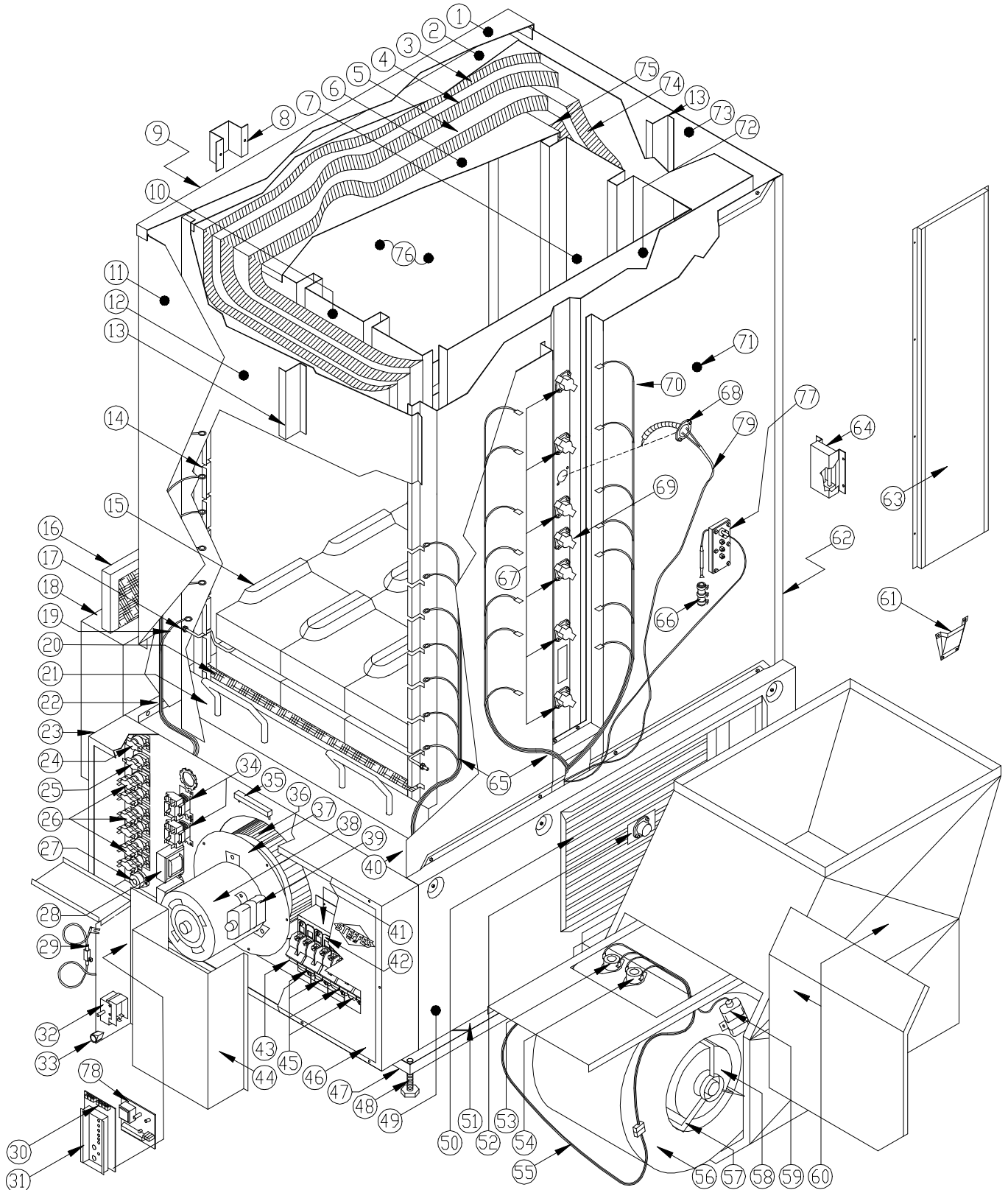



When ordering replacement parts, please include model number and serial number of the furnace.

DWG. REF. NO.	DESCRIPTION	DLF30B ITEM NO.	DLF40B ITEM NO.
1.	Painted Panel, Top	5940053	5940053
2.	Galvanized Top	5940055	5940055
3.	1" Blanket Insulation, Top & Front (Outer)	1050030	1050036
4.	2" Blanket Insulation, Top & Front (Middle)	1050031	1050037
5.	2" Blanket Insulation, Top & Front (Inner)	1050032	1050038
6.	Aluminized Top	5940062	5940062
7.	Stainless Steel Panel, Back	5940179	5940180
8.	Spacer Bracket	5940092	5940092
9.	Painted Panel, Left	5940056	5940057
10.	Aluminized Steel Panel, Front	5940270	5940271
11.	Painted Panel, Front	5940049	5940050
12.	Galvanized Front	5940059	5940060
13.	Galvanized Air Deflector	5940188	5940189
14.	Galvanized Back & Sides	5940069	5940035
15.	Heat Storage Brick (Whole)	5903002	5903002
	Heat Storage Brick (Half)	5903001	5903001
16.	Air Filter	1159012	1159012
17.	Heating Element (240V, 3200W)	1014016	1014016
	Heating Element (208V, 3200W)	1014018	1014018
	Heating Element (277V, 3200W)	1014020	1014020
18.	Filter Rack - Return Air	1022010	1022010
19.	Sequencer/Element Wiring Harness	1040021	1040006
20.	Hard Board Insulation, Base	1050060	1050061
21.	Tray Assembly	5940151	5940151
22.	Base Panel, Left	5940154	5940154
23.	Electrical Panel	5940176	5940176
24.	Stage 2 Time Delay Sequencer	1019000	1019000
25.	Stage 3 Time Delay Sequencer	1019004	1019004
26.	Charging Sequencers	1019002	1019002
27.	Heat Exchanger High Limit Switch Assembly (54")	1040058	1040058
28.	75 VA Control Transformer	1017039	1017039
29.	Volt Reduction Resistor Assembly	1040047	1040047
30.	Charge Control Circuit Board (SFIII)	1023005	1023005
31.	Control Board Mounting Plate	5940140	5940140
32.	Charge Control Thermostat Assembly	1040033	1040033
33.	Charge Control Knob	1154004	1154004
34.	Blower Relay	1018008	1018008
35.	Fan Speed Resistor	1017030	1017030
36.	Core Blower Wheel	1020002	1020002
37.	Core Blower Cover Plate Assembly	5940120	5940120
38.	Core Blower Motor Assembly (1/6 HP, 1360 RPM)	1040085	1040085
39.	Core Blower Motor Run Capacitor	1018004	1018004
40.	Front Angle, Top	5940046	5940046
41.	Circuit Breaker Standoff	5940034	5940034

Furnace Parts List (cont'd)

27



When ordering replacement parts, please include model number and serial number of the furnace.

DWG. REF. NO.	DESCRIPTION	DLF30B ITEM NO.	DLF40B ITEM NO.
42.	Circuit Breaker Bracket	1024010	1024010
43.	15 Amp Circuit Breaker	1024000	1024000
44.	Blower Cover Assembly	1190019	1190019
45.	60 Amp Circuit Breaker(s) (208V & 240V)	1024002	1024002
	60 Amp Circuit Breaker(s) (277V)	1024014	1024014
46.	Electrical Panel Cover	5940174	5940175
47.	Bottom Cover Panel, Base	5443022	5443022
48.	Leveling Leg	5575010	5575010
49.	Base Panel, Right	5940155	5940155
50.	Base Assembly	5941133	5941133
51.	Bottom Radiant Heat Shield	5443030	5443030
52.	135°F Blower Switch	1024008	1024008
53.	180°F Core Blower Limit Switch	1012010	1012010
54.	190°F Supply Air Blower Limit Switch	1012012	1012012
55.	Supply Air Blower Wiring Harness	1040004	1040004
56.	Supply Air Blower Assembly with Wheel	1021000	1021000
57.	Motor Mount Bracket	Call Factory	Call Factory
58.	Supply Air Blower Motor Assembly (1/2 HP, 1075 RPM)	1040086	1040086
59.	Supply Air Blower Motor Run Capacitor	1018006	1018006
60.	Supply Air Blower Plenum Assembly	1022008	1022008
61.	Limit Bar Channeling Plate	5940167	5940167
62.	Base Panel, Back	5940156	5940156
63.	Limit Bar Louvre Panel	5940152	5940153
64.	Outdoor Temperature Sensor Assembly	1040031	1040031
65.	Element/Limit Wiring Harness	1040022	1040005
66.	Charge Control Resistor	1017027	1017027
67.	Core Charging High Limit Switch Assembly	1040012	1040012
68.	Core Temperature Sensor	1043050	1043050
69.	Core Blower Speed Control Assembly	1040049	1040049
70.	Main Wiring Harness	1040023	1040024
71.	Painted Panel, Right	5940149	5940150
72.	Aluminized Side, Right	5940163	5940164
73.	Painted Panel, Back	5940049	5940050
74.	2" Blanket Insulation, Back & Sides (Outer)	1050033	1050039
75.	2" Blanket Insulation, Back & Sides (Inner)	1050034	1050040
76.	Aluminized Side, Left	5940165	5940166
77.	Temperature Sensing Bulb & Plate Assembly	1040033	1040033
78.	Auxiliary Control Board	1302036	1302036
79.	Auxiliary Controller Thermocouple Wire	1010380	1010380

1 BRICK CORE TEMPERATURE TESTING

An approximate brick core charge level in the furnace can be measured by taking a millivolt reading on the core temperature sensor. This sensor is located on the right side of the storage brick cavity in the limit bar louvre area. (See drawing reference #68 in the Exploded View Parts Diagram.) The millivolt reading (DC) can be compared to the Core Temperature Graph below to correlate the reading to an approximate brick core temperature. This reading is useful in determining proper core charging of the furnace.

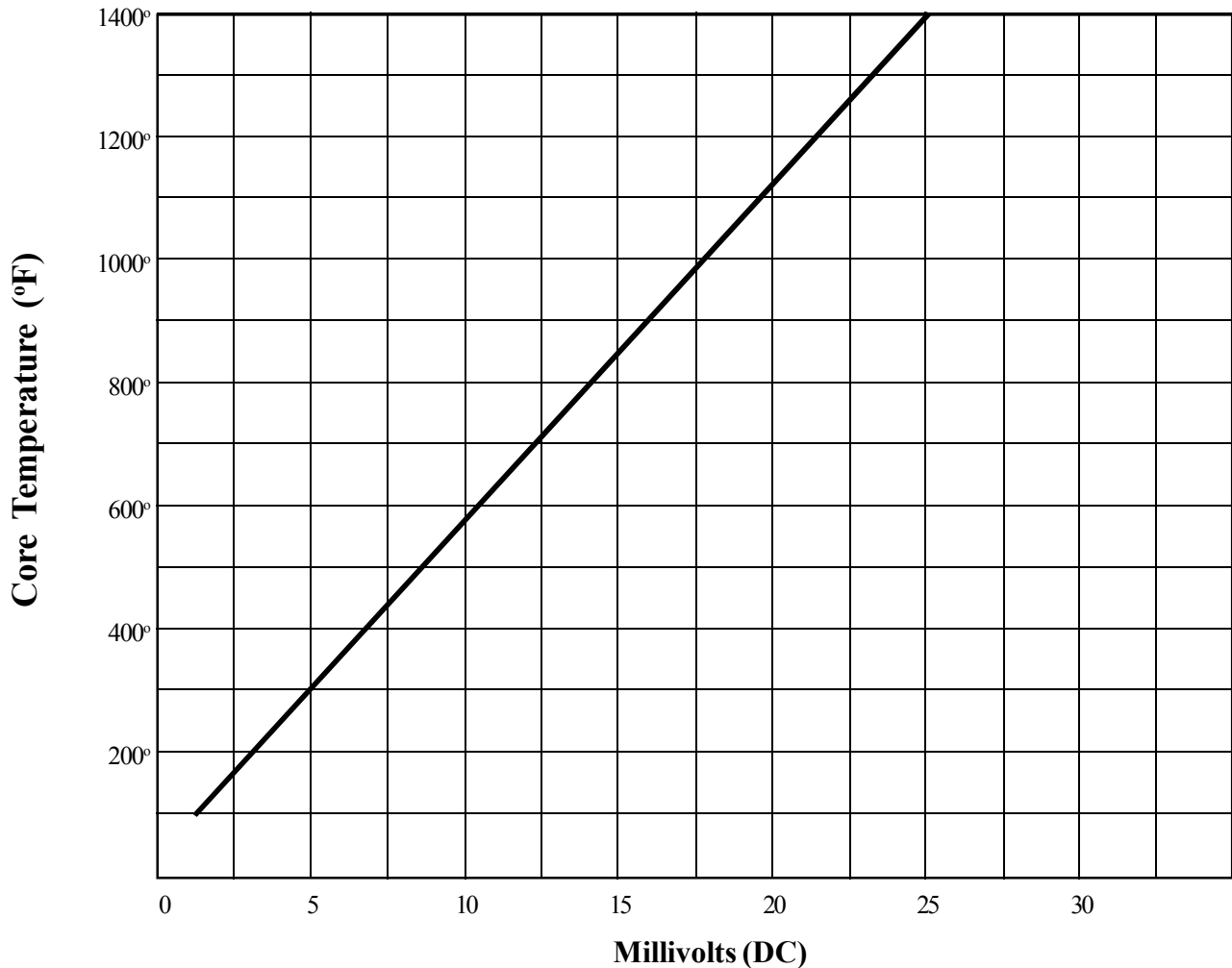

NOTE Maximum core charge temperature in normal operation is 1350°F (nominal).

2 TROUBLESHOOTING GUIDES

Before starting any of the troubleshooting procedures, check voltage on the load side of all the furnace circuit breakers. Also, check for 24 VAC between each of the 3-amp low voltage fuses and room thermostat terminal block "C" position on the charge control circuit board. These guides are based upon standard configuration of the furnace.



For cross reference to number coded components in each procedure, Refer to the Exploded View Parts Diagram in this manual.

Air Delivery

A. PROBLEM: SUPPLY AIR BLOWER WILL NOT RUN WITH FAN ONLY ROOM THERMOSTAT CALL

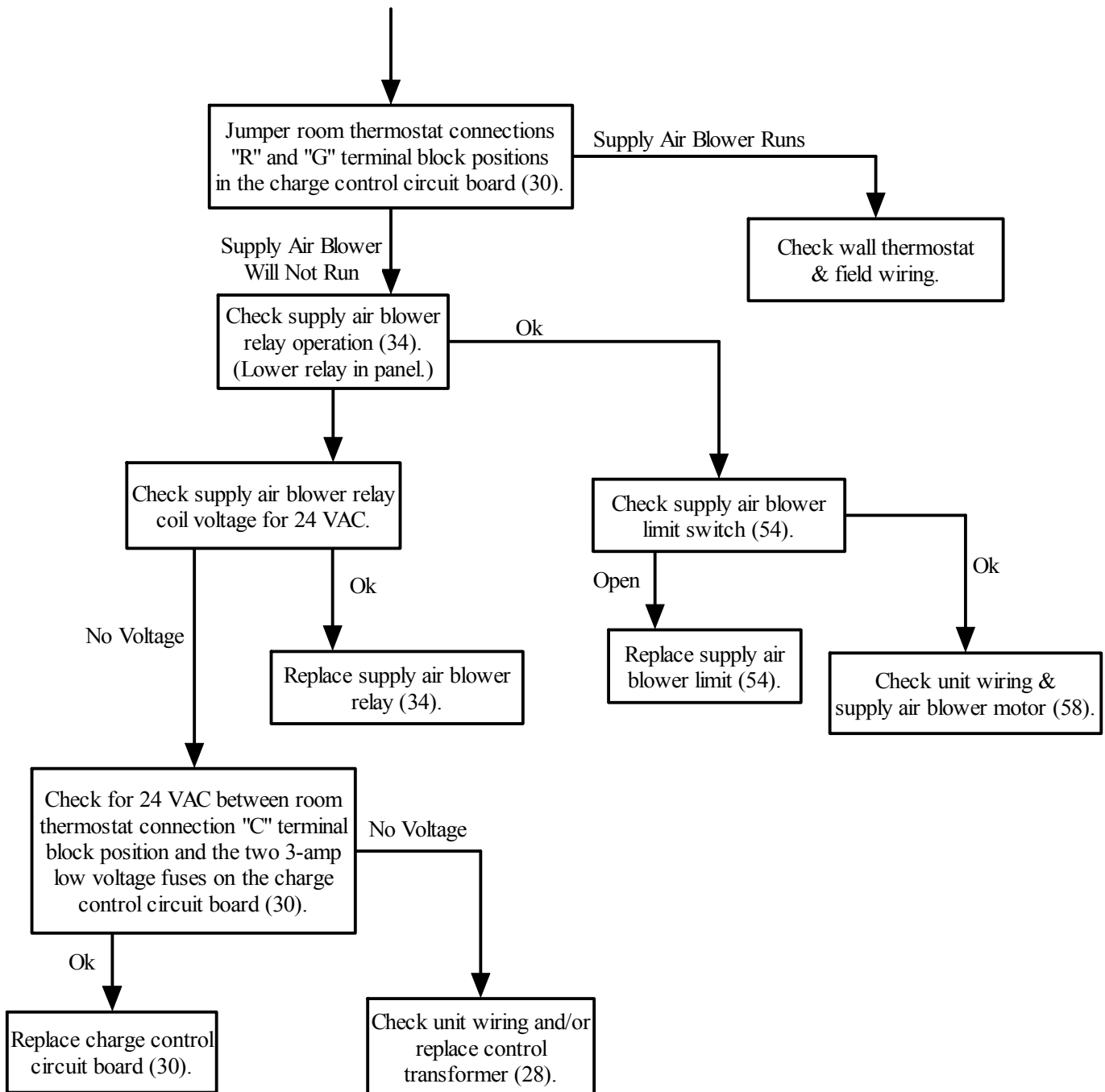

30 Troubleshooting Information (cont'd)

B. PROBLEM: FURNACE WILL NOT DELIVER HEAT

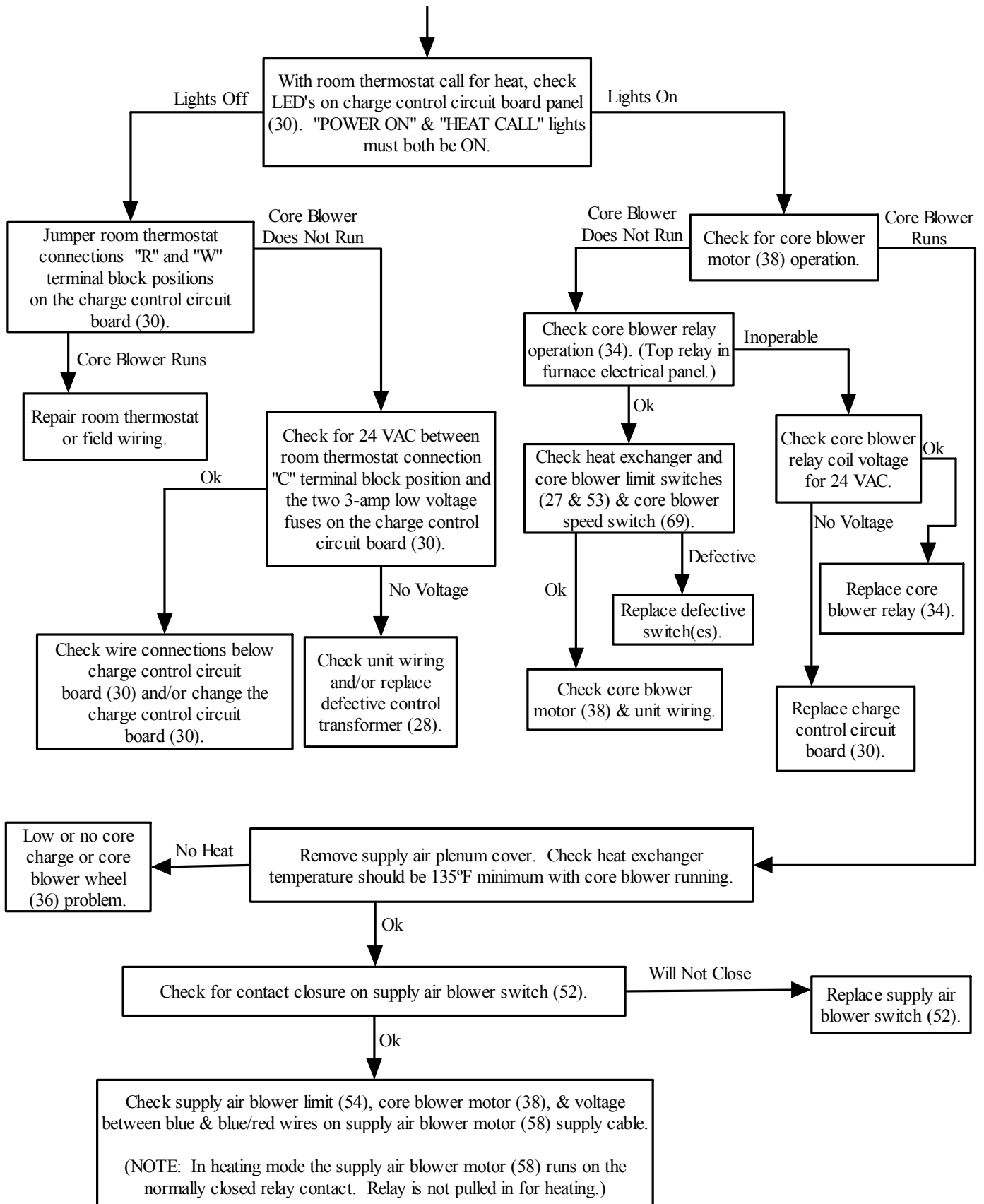

Core Charging

A. PROBLEM: FURNACE OVERCHARGES ON WARM DAY

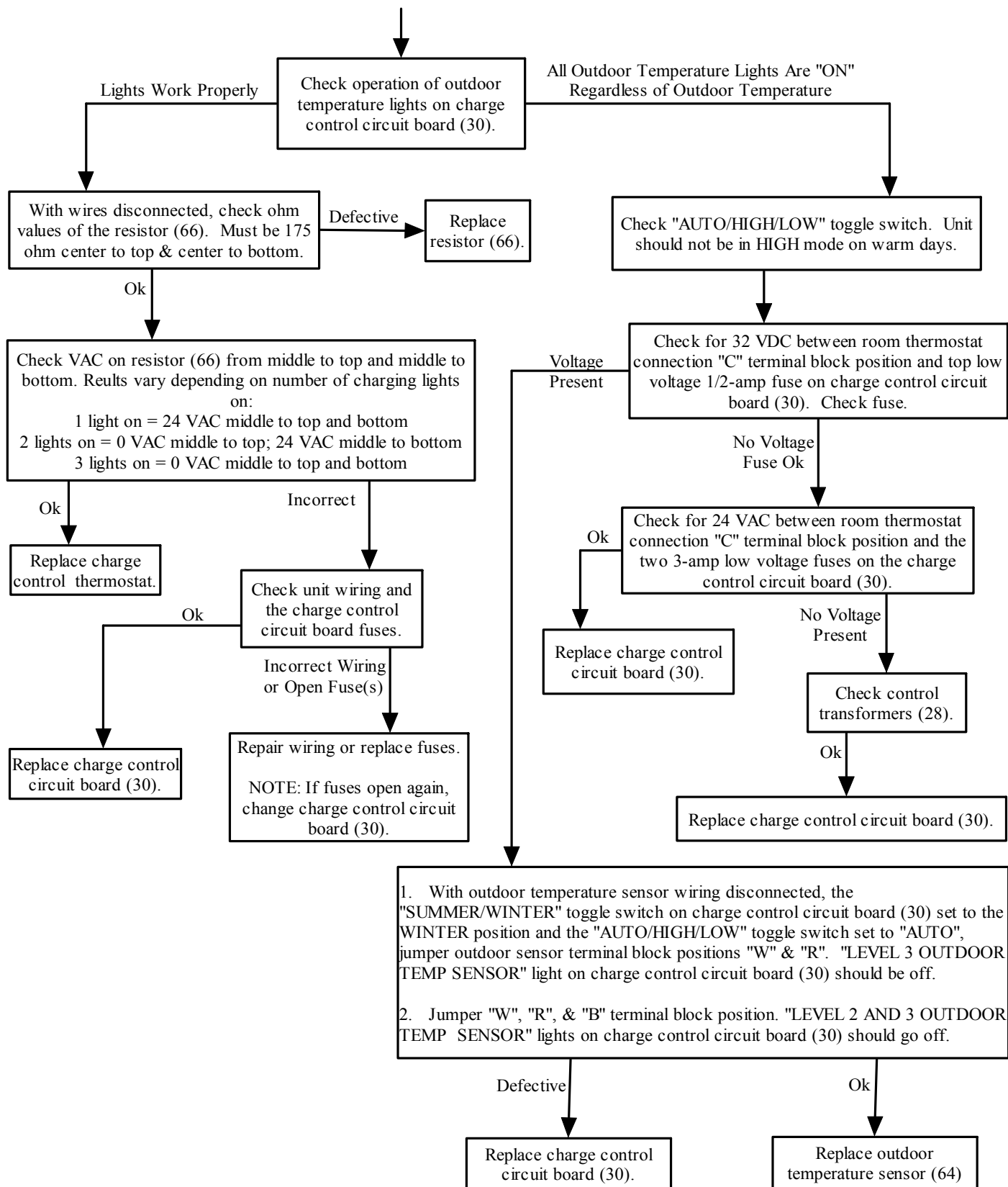

B. PROBLEM: FURNACE WILL NOT CHARGE (FURNACE HAS NO CORE CHARGE)

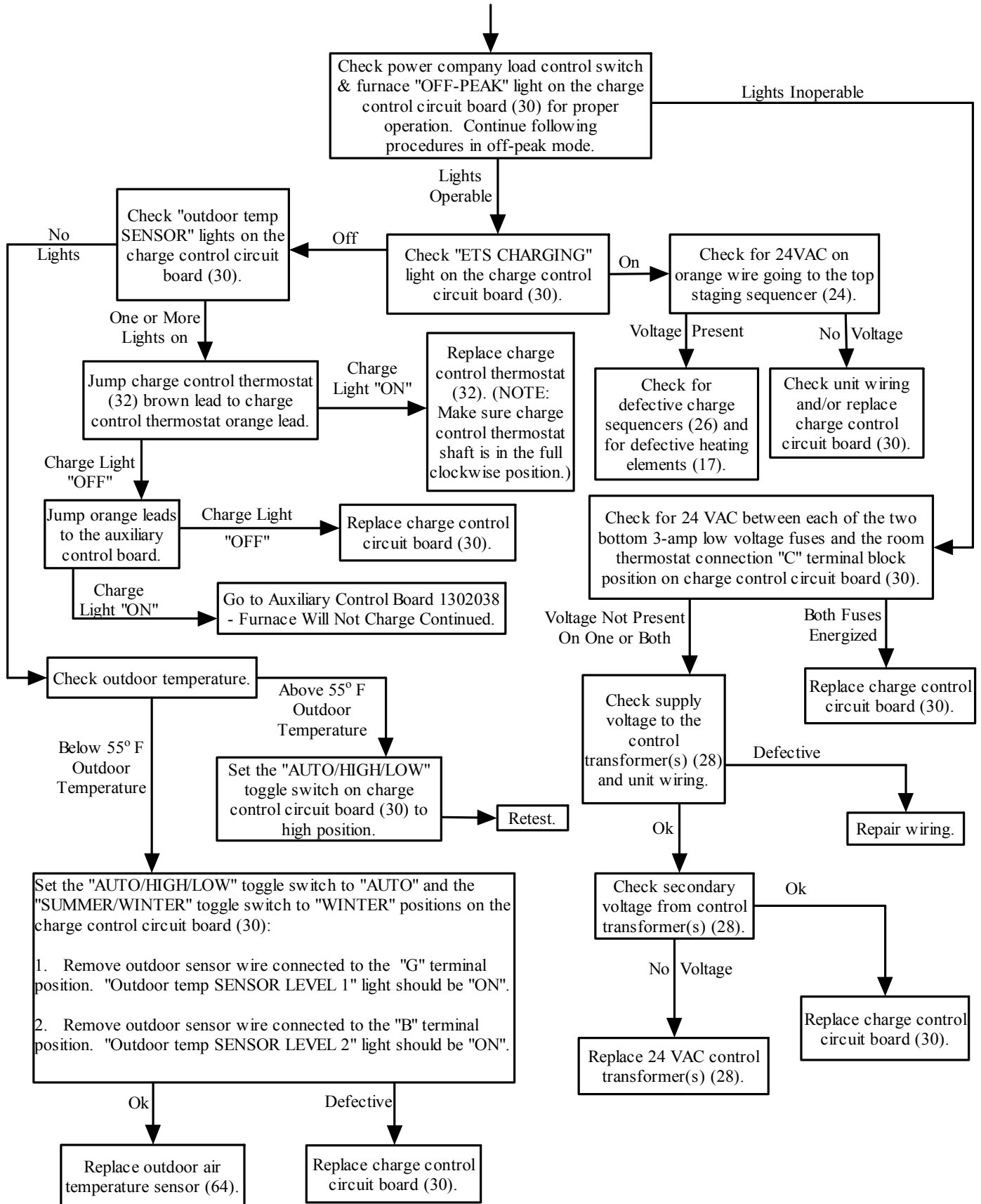

B. PROBLEM: FURNACE WILL NOT CHARGE (FURNACE HAS NO CORE CHARGE) continued...



This portion of the troubleshooting flow chart is to test operation of the auxiliary control board. Furnaces built after January of 1998 were produced with this additional control. If a system built before 1998 experiences element failure, Steffes recommends that the auxiliary control board be added as a supplemental controller for monitoring core temperatures in systems which have element failure.

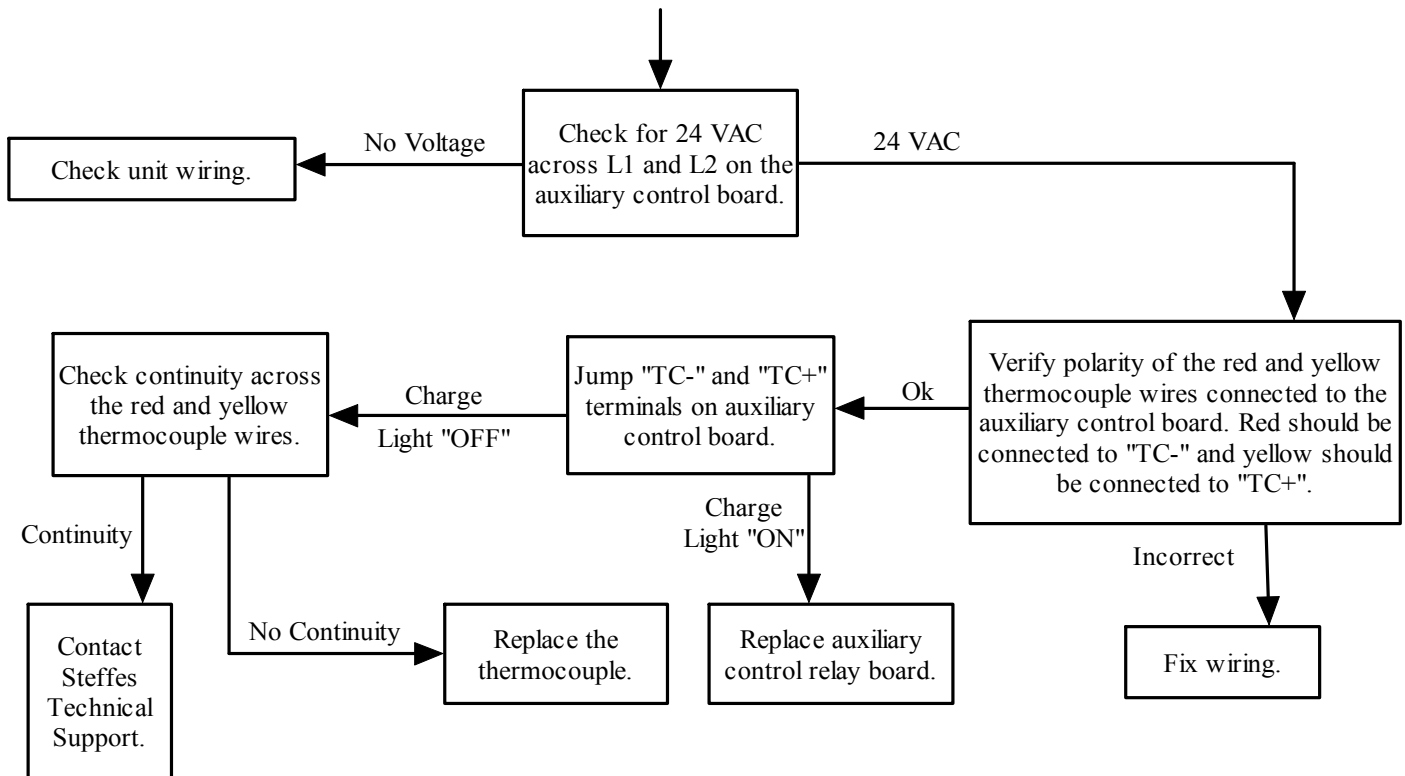

C: PROBLEM: FURNACE UNDERCHARGES

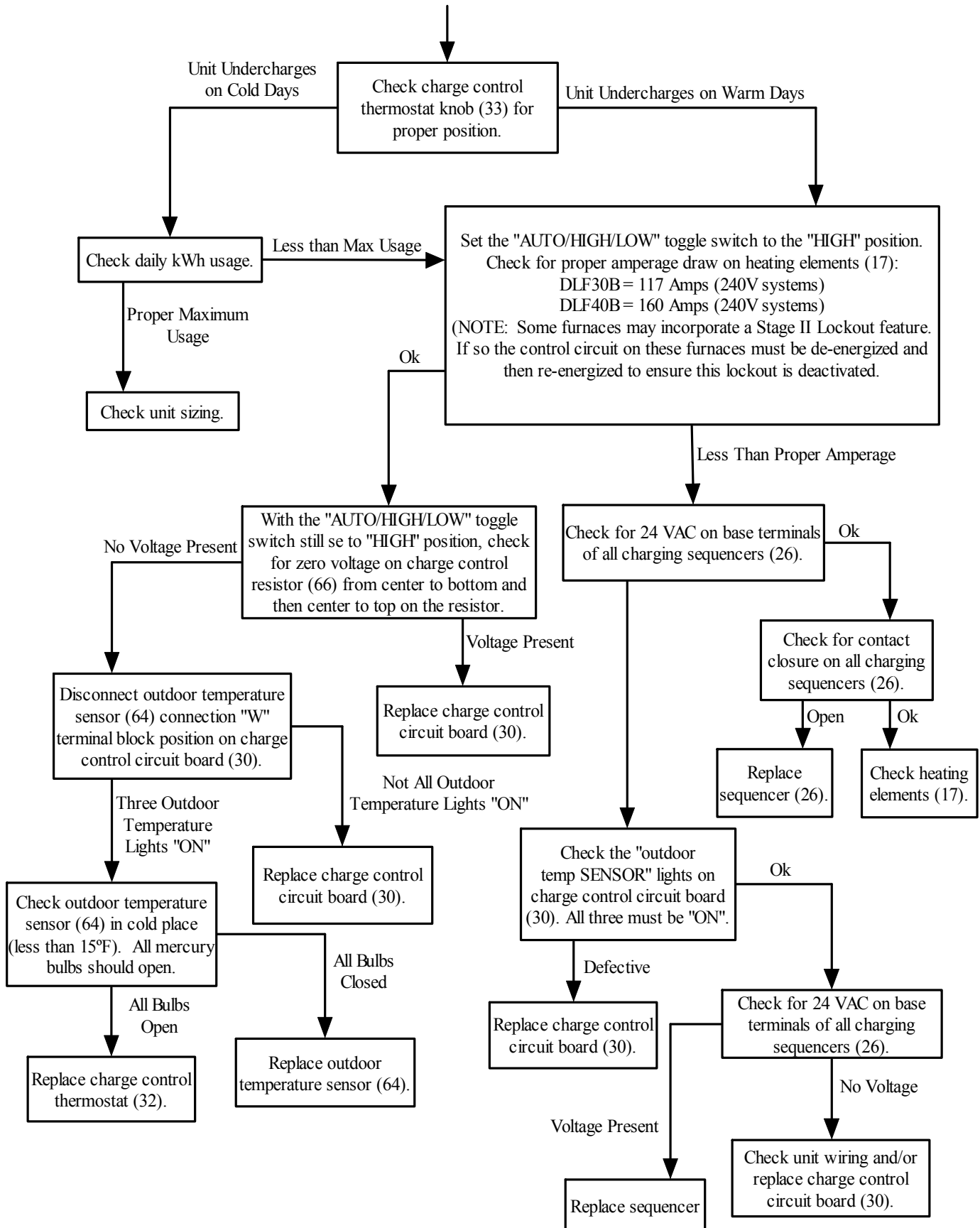

Warranty

Registering your purchase is an essential step to ensure warranty coverage. A Warranty Registration card is included with the Owner's Manual. Simply complete, detach the bottom portion, and return the card today. Retain the top portion of the card for your files.

Your Steffes product is protected by one of the most comprehensive warranties and outstanding service networks in the industry. We welcome comments you have relating to the equipment. Enjoy your new purchase!

Steffes Corporation ("Steffes") warrants that the Steffes Electric Thermal Storage Heating Appliance is free from defects in materials and workmanship under normal use and service. Steffes' obligation under this warranty is limited to the repair or replacement of the appliance or parts only which prove to be defective under normal use within **five (5) years** of the date of installation and which Steffes' examination of the returned appliance or part(s) shall verify to Steffes' satisfaction that it is defective. The user shall be responsible for any labor costs associated with the repair or replacement of the appliance or part(s), including the cost of returning the defective appliance or part(s) to Steffes Corporation.

This warranty is void if the heating appliance is moved from the premises in which it was originally installed. This warranty shall not apply to an appliance or part which has been altered in any respect, or improperly installed, serviced or used, or has been subject to accident, negligence, abuse or misuse.

THE ABOVE WARRANTY BY STEFFES IS EXCLUSIVE AND IN LIEU OF ALL OTHER WARRANTIES, WHETHER WRITTEN OR ORAL, EXPRESS OR IMPLIED, INCLUDING ANY IMPLIED WARRANTY OF MERCHANTABILITY OR OF FITNESS FOR A PARTICULAR PURPOSE.

The user assumes all risk and liability whatsoever resulting from the use of this heating appliance. In no event shall Steffes be liable for any indirect, special or consequential damages or lost profits.

This Limited Warranty contains the complete and exclusive statement of Steffes' obligations with respect to the heating appliance and any parts thereof. The provisions hereof may not be modified in any respect except in writing signed by a duly authorized officer of Steffes.



The equipment described herein is intended for installation in accordance with applicable local, state and national electrical codes and must be installed by a qualified electrician.

This manual should be retained by owner upon completion of the installation and made available to service personnel as required.

For Customer Use

Please record your model and serial numbers below. These numbers are located on the lower right side of the furnace base and on its supply air blower plenum assembly. Retain this information for future reference.

Model No. _____

Serial No. _____



3050 Highway 22 North • Dickinson, ND 58601-9413 • 701-483-5400