

## WARRANTY

Steffes Corporation (“Steffes”) warrants that the Steffes Power Line Carrier Transmitter is free from defects in materials and workmanship under normal use and service. Steffes’ obligation under this Warranty is limited to the repair or replacement of the appliance or parts only which prove to be defective under normal use within one (1) year of the date of installation and which Steffes’ examination of the returned device or part(s) shall verify to Steffes’ satisfaction that it is defective. The user shall be responsible for any labor costs associated with the repair or replacement of the device or part(s) including the cost of returning the defective appliance or part(s) to Steffes Corporation.

This Warranty is void if the transmitter device is moved from the premises in which it was originally installed. This Warranty shall not apply to a device or part which has been altered in any respect, or improperly installed, serviced or used, or has been subject to accident, negligence, abuse or misuse.

**THE ABOVE WARRANTY BY STEFFES IS EXCLUSIVE AND IN LIEU OF ALL OTHER WARRANTIES, WHETHER WRITTEN OR ORAL, EXPRESSED OR IMPLIED, INCLUDING ANY IMPLIED WARRANTY OF MERCHANTABILITY OR OF FITNESS FOR A PARTICULAR PURPOSE.**

The user assumes all risk and liability whatsoever resulting from the use of this transmitter. In no event shall Steffes be liable for any indirect, special or consequential damages or lost profits.

This Limited Warranty contains the complete and exclusive statement of Steffes’ obligations with respect to the transmitter and any parts thereof. The provisions hereof may not be modified in any respect except in writing signed by a duly authorized officer of Steffes.



3050 N Highway 22  
Dickinson, ND 58601-9413  
701-483-5400

“Commitment to Innovation”

DOCUMENT #1200114



# Operation & Installation Guide for Power Line Carrier Transmitter

(Applicable to Software Version 14.0-14.9)

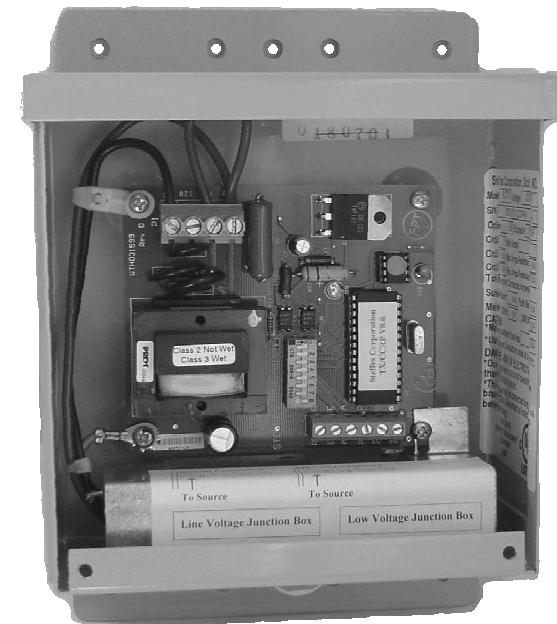

“Manufactured in North America”

## Off-Peak System Control





# TYPICAL SYSTEM WIRING DIAGRAM

## 208/240 VOLT, 3-PHASE SYSTEMS ONLY

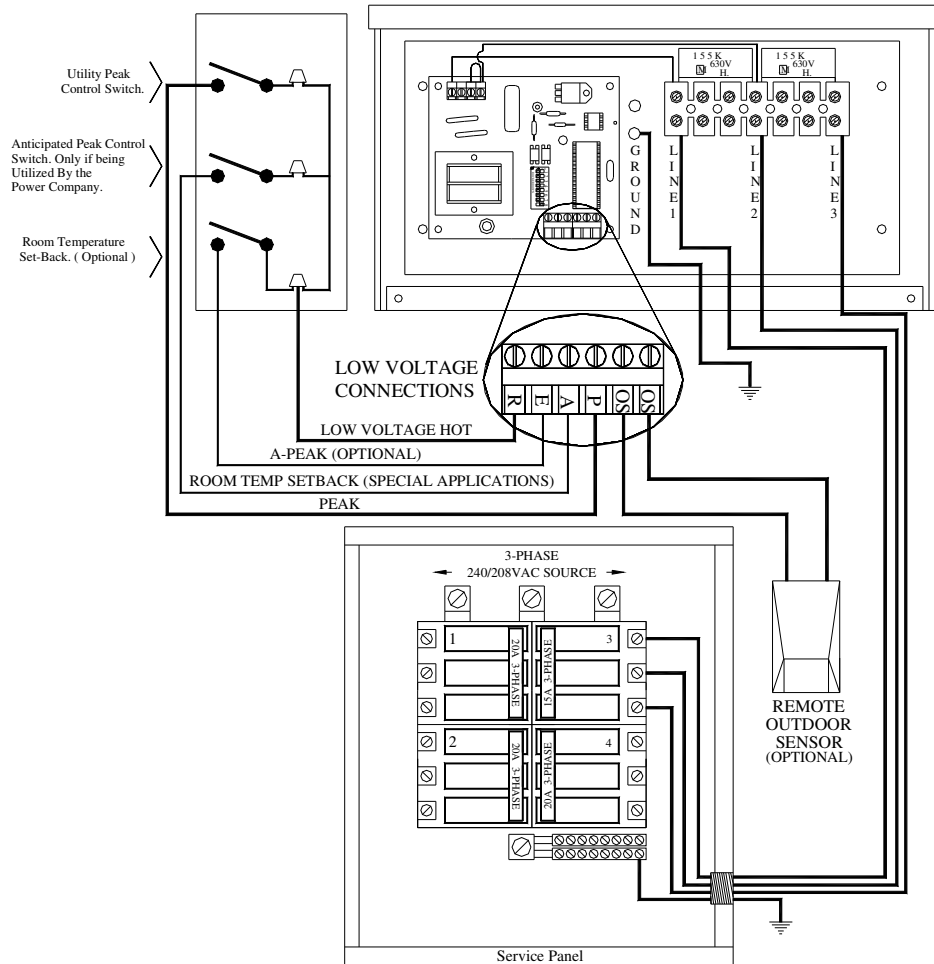

### NOTES:

1. To ensure proper communications between the PLC transmitter and the controllable electrical loads, the transmitter **MUST** be grounded.
2. The system grounding and bonding must be sized and installed in compliance with all applicable codes.
3. The transmitter in this diagram is shown connected directly to the service panel. However, any appropriately sized uninterrupted branch circuit can be used to power the transmitter.



## WARNING

**HAZARDOUS VOLTAGE:** Risk of electric shock, injury, or death. System may be connected to more than one branch circuit. Disconnect power to all circuits before servicing. Equipment must be installed and serviced by a qualified technician.



## IMPORTANT

- ◆ The equipment described herein is intended for installation by a qualified technician in accordance with applicable local, state, and national codes and requirements.
- ◆ This manual should be retained by the owner upon completion of the installation and made available to service personnel as required.
- ◆ Disclaimer:
  - Conditions may occur which cause the power line carrier transmitter and receivers to have difficulties communicating; therefore, not operating properly. In no event shall Steffes Corporation be liable for any indirect, special, or consequential damages or lost profits.
  - In compiling this manual, Steffes Corporation has used its best judgement based upon information available, but disclaims any responsibility or liability for any errors or miscalculations contained herein, or any revisions hereof, or which result, in whole or in part, from the use of this manual or any revisions hereof.

### FOR CUSTOMER USE

Please record the serial number of the transmitter below. This information is located inside the transmitter enclosure. Retain this information for future reference.

Serial No. \_\_\_\_\_

## TABLE OF CONTENTS

<b>General Operation</b> .....	1
<b>Installation</b> .....	1-4
Line Voltage Connections .....	1-2
Peak Control .....	2
Circuit Board Configuration .....	2
Outdoor Temperature Sensor .....	3
Indicator Lights .....	3
Room Temperature Set Back .....	3
Anticipated Peak .....	4
<b>Dip Switch Settings</b> .....	4-6
<b>Installer's Final Check Out Procedure</b> .....	7-8
<b>Typical System Wiring Diagram (Single Phase)</b> .....	9
<b>Typical System Wiring Diagram (3-Phase)</b> .....	10

## FEATURES

The PLC transmitter is an accurate and reliable device offering the following features:

- ◆ Operates on 120V or 208V/240V, single phase.
- ◆ Pre-wired 16 AWG leads for line voltage field connections.
- ◆ A 6" x 6" x 3" rainproof metal enclosure with power company seal/lockout provision for indoor or outdoor installations. A three phase system in a 12" x 6" x 3" rainproof metal enclosure is available as a special factory order.
- ◆ Fifteen (15) selectable communication channels.
- ◆ Wireless control of an unlimited number of Steffes microprocessor based heating systems and any controllable devices with the correlating receiver.
- ◆ Capable of transmitting:
  - Peak Control Signals
  - Outdoor Temperature Information (Automatic Charge Control)
  - Room Temperature Set Back Information (requires an external signaling device, not included)
  - Anticipated Peak (pre-peak) Control Signals

## TYPICAL SYSTEM WIRING DIAGRAM SINGLE PHASE (208/240 Volt or 120 Volt)

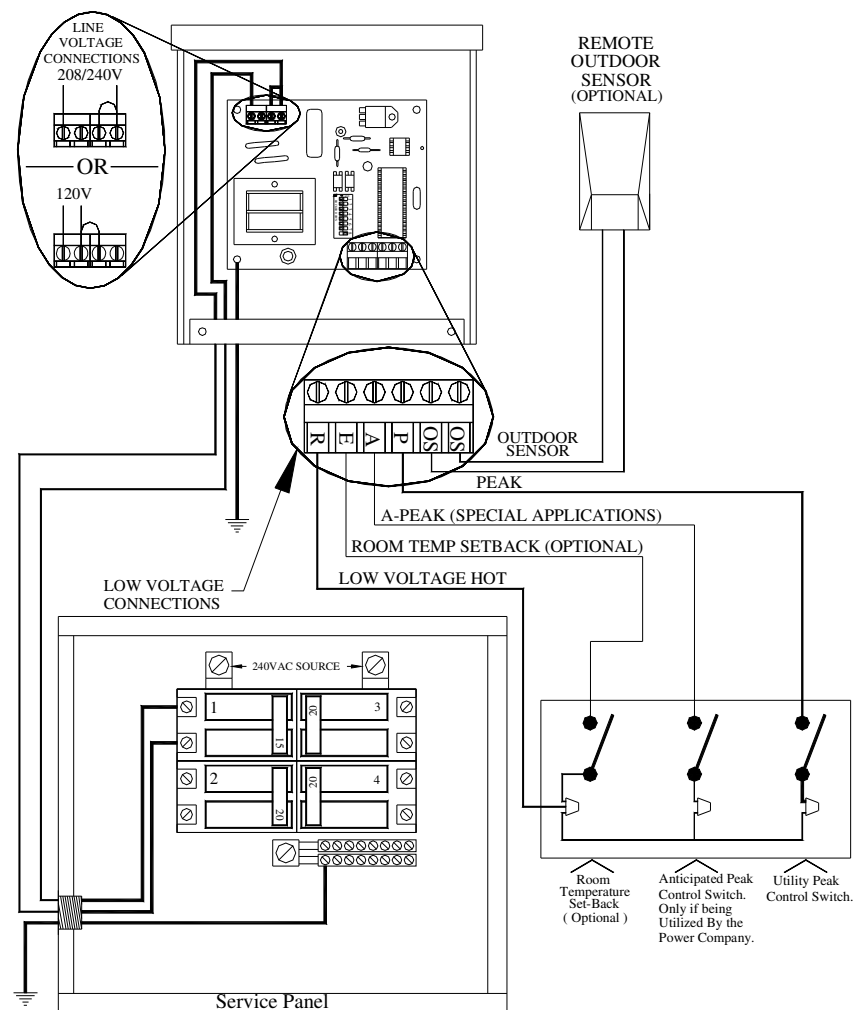

### NOTES:

1. To ensure proper communications between the PLC transmitter and the controllable electrical loads, the transmitter **MUST** be grounded.
2. The system grounding and bonding must be sized and installed in compliance with all applicable codes.
3. The transmitter in this diagram is shown connected directly to the service panel. However, any appropriately sized uninterrupted branch circuit can be used to power the transmitter

## INTERFACING THE TRANSMITTER WITH THE STEFFES 1000 and 2000 SERIES ROOM HEATING UNITS:



All heater locations referenced below are accessed through the faceplate on the front of the 1000/2000 Series heater. Refer to the Owner's Manual for operating instructions.

1. Verify that the heater is operating on the same channel as the transmitter by checking the setting in Location 11 (L11) of the heater. The heater is factory preset to operate on channel 1.
2. Once good communication is established between the transmitter and the heater, the lower right indicator light on the heater's faceplate illuminates green continuously.
3. If utilizing the transmitter's automatic charge control features, compare the information in Location 46 (L46) of the heater's control circuit board to the actual outdoor temperature. This location will display a hex value approximating the current outdoor temperature. If the temperature information in L46 is reading substantially higher or lower than actual outdoor temperature, refer to Dip Switch Settings 7 and 8.



If the transmitter is installed indoors and automatic charge control is desired, a remote outdoor sensor is required.

## INTERFACING THE TRANSMITTER WITH THE STEFFES 2100 SERIES AND COMFORT PLUS SYSTEMS:



The "Help Menu" on the heater is accessed through the faceplate on the front of the heater. Refer to the Owner's and Installer's Manual for operating instructions.

Using the "Help Menu" on the heater's control panel:

1. Verify that the heater is operating on the same channel as the transmitter. The 2100 Series heater is factory preset to operate on channel 1. Comfort Plus systems are not factory preset for power line carrier.
2. Verify that power line carrier communication is occurring.
3. If utilizing the transmitter's automatic charge control features, compare the outdoor temperature information from the "Help Menu" to current outdoor temperature. If the temperature information in the help menu is substantially higher or lower than actual outdoor temperature, refer to Dip Switch Settings 7 and 8.

## GENERAL OPERATION

The Steffes Power Line Carrier (PLC) Transmitter is a device used for communicating information through the local electric circuits to an unlimited number of Steffes microprocessor based heating systems (1000, 2000, 2100, 3100, 4100, and 5100 Series) and other controllable devices incorporating the Steffes PLC receiver. A receiver is built into Steffes microprocessor based heating systems, so the transmitter can communicate directly with the equipment without the cost of additional controls or electrical wiring. Therefore, overall installation costs of an ETS system can be significantly reduced, especially in multiple unit installations and projects such as hotels, motels, apartments, condos, etc.

The transmitter must be wired into the line voltage power serving the installation. The transmitter continuously sends information through the local electric circuits. This information is received by the Steffes heating equipment and other controllable devices with a correlating receiver, provided they are on the same power company distribution transformer as the transmitter.

## INSTALLATION

Mount the transmitter in the desired location.



If utilizing the built-in outdoor temperature sensing thermistor, it is important to place the transmitter in an area where it will NOT be exposed to direct sunlight.

### Line Voltage Connections

This device can be connected to 120V or 208V/240V, single phase.



In most applications, optimum performance is achieved when connected to 208V/240V.

The PLC transmitter is factory configured for 208V/240V field connections. DO NOT connect the transmitter to 277V unless the identification label indicates it is suitable for 277V. A three-phase option is available as a special order.

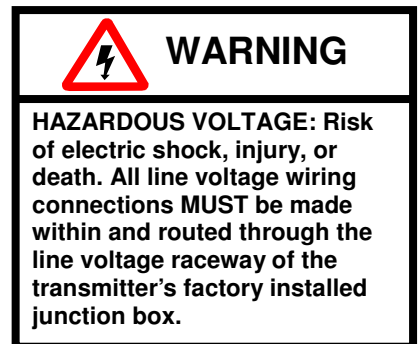

## INSTALLATION CONTINUED...

If the transmitter is to be connected to 120V, transformer tapping **MUST** be changed. To change transformer tapping to 120V, move the black wire jumper to positions P2 and 110 in the line voltage terminal strip. Move the factory installed line voltage connections to the 110 and L1 positions in the line voltage connections terminal strip. (See Circuit Board Configuration below for reference to proper placement of the jumper and wires.)

### Peak Control

Connect the peak control signaling device to the "R" and "P" terminals on the low voltage terminal strip.

### Circuit Board Configuration

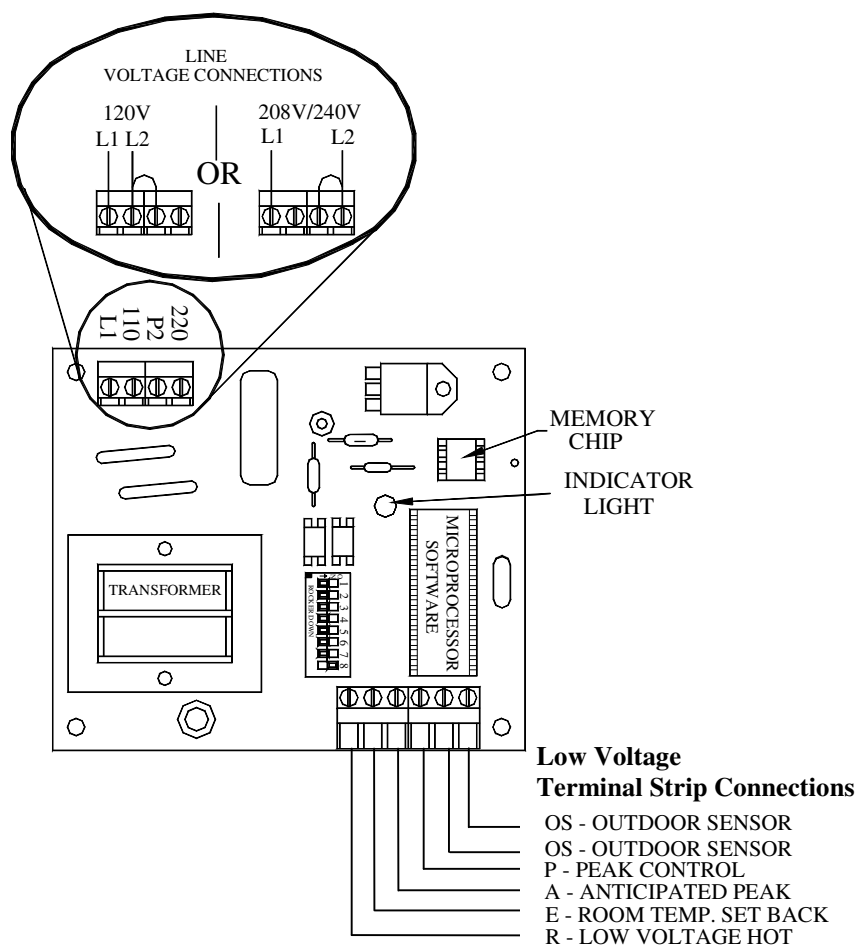

## INSTALLER'S FINAL CHECK OUT PROCEDURE

1. Prior to energizing the electrical circuit feeding the transmitter, inspect all field installed electrical connections to ensure they are tight and all wires are routed correctly. All line voltage wiring connections must be made within and routed through the line voltage raceway of the factory-installed junction box. To ensure proper communication, the transmitter must be grounded.



**The transmitter is factory configured for 208V/240V field connections. If using 120V input, transformer tapping must be changed. (Refer to the Circuit Board Configuration Diagram.)**

2. Make sure the dip switch settings on the transmitter are in the correct positions for the application. Remember, the desired PLC channel **MUST** be selected for communication to occur.
3. Activate the utility peak control device and energize the transmitter. Verify that the indicator light on the transmitter is illuminated and corresponds with the utility peak signal (flashing for off-peak or continuous illumination for on-peak).
4. Invert dip switch #1 on the transmitter. If the indicator light was flashing in Step 3, it should now illuminate continuously. If the light had been illuminated, it should now begin to flash. Return dip switch #1 to the proper position for the application.
5. Use the guidelines which follow to verify the transmitter is communicating with all receivers in the application (microprocessor based heaters and Steffes mini receiver configurations).



**Communication between the transmitter and receiver occurs on a continuous basis. Upon energizing a system, there will be some delay in a receiver's response to the transmitter's signal. It takes approximately seven (7) minutes to establish initial communication. Subsequent communication will occur more rapidly.**

### INTERFACING THE TRANSMITTER WITH THE STEFFES MINI RECEIVER (single, double or six pole configurations):

Once the mini receiver is receiving complete information from the transmitter, the red indicator light on the mini receiver will illuminate continuously. Refer to the Operation and Installation Guide for the Mini Receiver to perform the checkout procedure for this device and ensure correct installation and operation.

### DIP SWITCH 6: NOT USED IN PLC TRANSMITTER

FACTORY DEFAULT SETTING = OFF

### DIP SWITCH 7: NEGATIVE OUTDOOR TEMPERATURE CALIBRATION

This dip switch is used to calibrate the outdoor temperature sensor information **DOWNWARD** if it is reading **HIGHER** than the actual outdoor temperature.

FACTORY DEFAULT SETTING = OFF

Off = Standard operating position.

On = A negative 5°F (-5°F) outdoor temperature calibration will be applied.

### DIP SWITCH 8: POSITIVE OUTDOOR TEMPERATURE CALIBRATION

This dip switch is used to calibrate the outdoor temperature sensor information **UPWARD** if it is reading **LOWER** than the actual outdoor temperature.

FACTORY DEFAULT SETTING = OFF

Off = Standard operating position.

On = A positive 5°F (+5°F) outdoor temperature calibration will be applied.

### Outdoor Temperature Sensor

The outdoor sensor provides outdoor temperature information to the transmitter which in turn sends these signals, wireless, to the microprocessor based heating systems. The heater's brick core temperature target level adjusts automatically in relation to outdoor temperature.

A temperature sensing thermistor is connected to the two "OS" positions of the low voltage terminal strips for automatic charge control of ETS heaters. This sensor can be utilized if the transmitter is mounted in a location where it can accurately sense the outdoor temperature and will not be affected by direct sunlight or other sources of heat and cold. The temperature sensor may be affected by heat generation from inside the enclosure. However, in most applications, it provides suitable outdoor temperature sensing.



**If the transmitter is installed indoors and automatic charge control is desired, a remote outdoor sensor is required. This outdoor sensor connects to the two "OS" positions of the low voltage terminal strip in the transmitter. The existing thermistor MUST be removed before connecting a remote mounted outdoor sensor.**

### Indicator Light

When the circuit board is energized, the indicator light should always illuminate, either in a flashing mode or in a continuous illumination mode, to indicate the microprocessor is processing information. The various illuminations of this light are described below:

**No Illumination:** The microprocessor is unable to process information. Check for proper system wiring.

**Continuous Illumination:** Will occur anytime a peak control signal is being received.

**Slow Flash (4 second duration):** Will occur during off-peak times.

The illumination time of the light is in direct relation to the temperature information the transmitter is receiving from the outdoor temperature sensor. A long illumination time indicates warmer temperatures and a short illumination time indicates colder temperatures.

### Room Temperature Set Back

If using the PLC transmitter with the Steffes microprocessor based heating equipment and utilizing the automatic room temperature set back option, the addition of a signaling device is required to initiate the set back time. This signaling device connects to the "R" and "E" input positions of the terminal strip in the transmitter. When the transmitter receives the set back signal, it sends that signal, wireless, to the heater(s). The heater(s) respond by maintaining the set back temperature programmed into them. A closed switch indicates room temperature set back is enabled.

**Anticipated Peak**

Typically, power companies are capable of sending one signal for peak control of selected devices. There are some instances; however, where power companies are capable of sending multiple signals for control purposes. In these situations, it is possible to have on-peak hours, off-peak hours, and anticipated peak (pre-peak) hours.

**On-peak** hours are times during which a controllable load is disabled.

**Off-peak** hours are times during which a controllable load is allowed to operate. **Anticipated (pre-peak)** hours are times during which ETS equipment can be prepared for an up coming on-peak (control) period, or a time when power companies can apply customized control of the ETS equipment.

Power companies selectively use anticipated peak (pre-peak) signals. If uncertain as to whether this option is being utilized in your area, contact your local power company representative.

**DIP SWITCH SETTINGS**

If the transmitter is being utilized with the Steffes 1000 and/or 2000 Series heater(s), all dip switches on the heater’s main control circuit board **MUST** be set to the “OFF” position except dip switches 5 and 7. These can be in the “OFF” or “ON” position, depending on the application.

**DIP SWITCH 1: INVERT PEAK**

This dip switch is used to match the Steffes 1000, 2000, 2100 Series room heaters, the Comfort Plus, or any device wired to the Steffes PLC receiver for peak control purposes to the utility’s signaling device.

FACTORY DEFAULT SETTING = ON

Off = An open utility switch signals an off-peak time to the heater (charging is enabled in the ETS heater). A closed utility switch signals an on-peak time (charging is disabled in the ETS heater).

On = A closed utility switch signals an off-peak time to the heater (charging is enabled in the ETS heater). An open utility switch signals an on-peak time (charging is disabled in the ETS heater).

**DIP SWITCH 2, 3, 4 and 5: TRANSMIT CHANNEL**

The transmitter is capable of transmitting on one of fifteen channels. The dip switch settings in the Steffes PLC transmitter **MUST** be set to match the channel setting of the receiving device(s).

To select the power line carrier communication channel desired, use the chart below and set dip switches 2, 3, 4 and 5 to the appropriate positions. If dip switch 2, 3, 4, and 5 are all set to the "OFF" positions, the transmitter will not transmit a power line carrier signal.

FACTORY DEFAULT = Channel One (2 ON, 3 OFF, 4 OFF, 5 OFF)

CHANNEL	DIP SWITCH #2	DIP SWITCH #3	DIP SWITCH #4	DIP SWITCH #5	CHANNEL SPEED
0	OFF	OFF	OFF	OFF	N/A
1	ON	OFF	OFF	OFF	SLOW
2	OFF	ON	OFF	OFF	SLOW
3	ON	ON	OFF	OFF	FAST
4	OFF	OFF	ON	OFF	FAST
5	ON	OFF	ON	OFF	FAST
6	OFF	ON	ON	OFF	FAST
7	ON	ON	ON	OFF	FAST
8	OFF	OFF	OFF	ON	FAST
9	ON	OFF	OFF	ON	FAST
10	OFF	ON	OFF	ON	FAST
11	ON	ON	OFF	ON	FAST
12	OFF	OFF	ON	ON	SLOW
13	ON	OFF	ON	ON	SLOW
14	OFF	ON	ON	ON	SLOW
15	ON	ON	ON	ON	SLOW



1. **1000/2000 Series heaters will ONLY receive on slow speed channels.**
2. **If multiple transmitters are installed on the same distribution transformer, do not use both channels one (1) and two (2).**